

A person wearing a blue hoodie and khaki shorts is captured in the middle of a disc golf throw on a paved path. The path is surrounded by tall, thin trees, likely pines, with sunlight filtering through the leaves. The person is holding a disc in their right hand, ready to throw it. The background shows a dense forest of similar trees, creating a serene and natural setting for the activity.

# Disc Golf For The UC Davis Arboretum: A RECREATIONAL WALK AROUND THE WORLD

BY ERIK NOEL REYES

# UC Davis Arboretum: A RECREATIONAL WALK AROUND THE WORLD

2013 Senior Project - Erik Noel Reyes

A Senior Project Presented to the faculty of the Landscape Architecture Program, University of California, Davis  
in fulfillment of the requirement for the Degree of Bachelors of Science in Landscape Architecture.

Accepted & Approved by:

---

Stephen Wheeler, Senior Project Advisor

---

James Oates, Committee Member

---

Byron McCulley, Committee Member

---

Haven Kiers, Committee Member

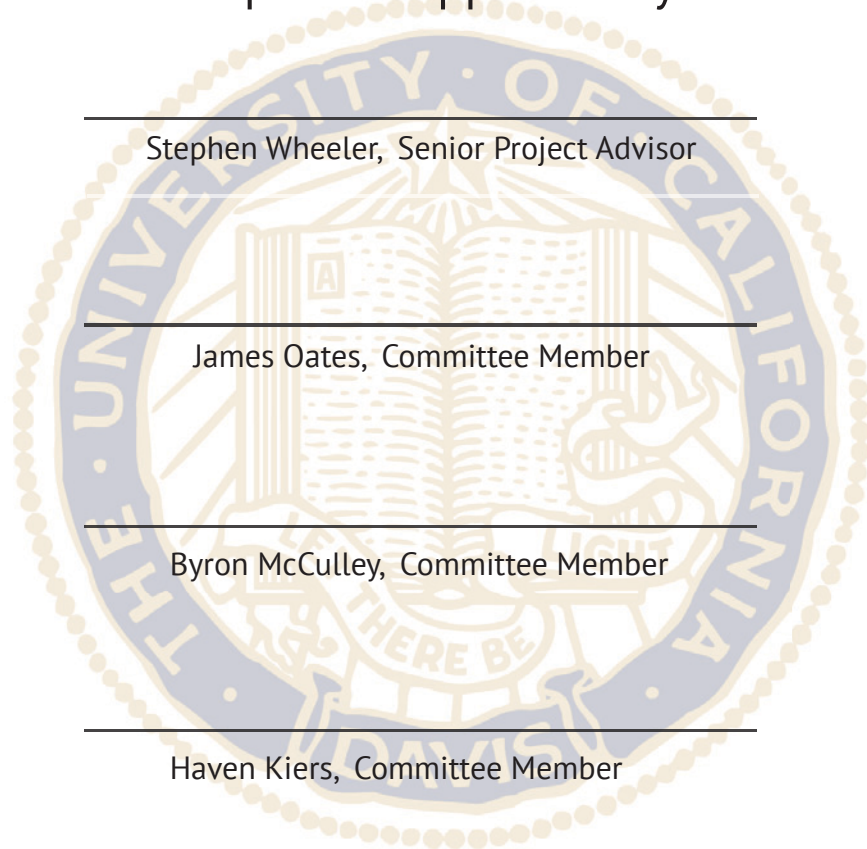

# PREFACE

---

Throughout my college career, I have learned about the need to design landscapes that are multi-functional, safe, and that respect the existing environment that surrounds us. I have come to understand that creating places that encourage physical activity within neighborhoods is crucial to human health. Through the Landscape Architecture program, I have also learned that we are one of many ways by which regions, counties, neighborhoods and the people within them, are able to express their needs.

The idea of designing a disc golf course first came to be while I was playing disc golf last summer. I have been playing disc golf for 6 years and, through my experience

at many different courses, I could not help but notice that some courses lack ingenuity, functionality, appeal to the user, and safety. Disc golf, in the last decade, has become one of the fastest growing sports in the United States and has expanded to other countries in Europe and the America's. It is free , unlike many other sports and players of any race, age or gender can play. Also, it has little to no impact to the environment.



---

# ABSTRACT

---

This project serves as a suggested master plan of a disc golf course for the UC Davis Arboretum. The course will encompass the west end of the Arboretum. The focus is to provide a healthy recreational outlet for students and community members, and to educate students about the various lifetime benefits disc golf has to offer by providing a lesson plan that will focus on basic skills of disc golf, with an emphasis on the educational value of the Arboretum. The design will include seventeen holes, natural sitting spaces made from recycled stumps, natural enhancements to make for better game play, and carefully placed signage to increase safety for all users.

The process of developing this course included a review of historical information about course design strategies, growth and benefits of the sport of disc golf, history of the Arboretum, and various visits to other courses around California in order to develop a clear understanding of what makes a course successful. In order to reach my goal, I conducted various interviews with professionals, casual players, shop owners, course designers, and Arboretum staff. Design elements aim to highlight the beauty of the Arboretum, education about the sport of disc golf, and the enjoyment of the game.

# ACKNOWLEDGEMENTS

---

I would like to thank the disc golf community for welcoming into their group and sharing their views and knowledge of the sport.

Thanks to Gayle Totten for her constructive advice throughout m project.

Thanks to my committee members: Jim Oates & Byron McCulley for their suggestions, advice and time they spent listening to my ideas.

Finally, thanks to all of my classmates who made this past three years memorable. I wish you all the best of luck!! GRACIAS!

# DEDICATION

---

## A mis padres queridos

Yo me acuerdo que desde que llegamos a este país y mucho más antes ustedes siempre nos dieron la mejor educación en casa y en la escuela. Ustedes dejaron de cuidarse a ustedes mismos para proveer para nosotros. Dejaron nuestro querido México para darnos mejores oportunidades sin saber si volverían a ver a sus propios padres. Yo soy quien soy por los valores que nos inculcaron desde pequeños y hoy en este día que marca el largo camino que hemos tenido en estos últimos trece años les quiero dedicar este éxito con todo mi corazón. Estaré eternamente agradecido. Mami y papi los quiero muchísimo.

## A mi familia en México

A mi nunca se me va a olvidar la ayuda que nos dieron a mí y a mi hermano cuando no teníamos a dónde vivir. Tengo muchos bonitos recuerdos de cuando nos los pasábamos juntos en días festivos. A sido difícil no verlos por trece años. Gracias por sus oraciones e interés en mi éxito aquí en los Estados Unidos. Tía Lupe, yo sé que en este día te encuentras enferma y no sabes lo que me duele no poder visitarte. A ti también te quiero dedicar este éxito. Gracias por todo tu amor

## To Christine Hopper

I would just like to say thank you from the bottom of my heart. Ever since I met you, you have encouraged me to be a better person to my family and even strangers. You have taught me very valuable life lessons that I was too busy to understand. You have showed me beautiful places that you knew I would enjoy because of my appreciation for the outdoors. Finally, you have gone out of your way to help me on those sleepless nights, helping me edit my writing, giving me input on my projects, and the list goes on. Due to your circumstances, you have not been able to graduate and I know that means a lot to you. So I dedicate this to you! I love you.

# TABLE OF CONTENTS

## PART 01

Pg. 2-31

### RESEARCH

HISTORY OF DISC GOLF  
SPORT DESCRIPTION  
OVERALL FEASIBILITY  
DESIGN STRATEGIES  
BENEFITS  
INFOGRAPHICS:  
WHY PLAY?  
WHO PLAYS?  
WHERE TO PLAY?  
DISC GOLF COURSE GROWTH  
CASE STUDIES  
EDGE

## PART 02

Pg. 33-47

### ANALYSIS

SITE CONTEXT  
ARBORETUM HISTORY  
SITE ANALYSIS  
OPPORTUNITIES & CONSTRAINTS:  
PHASE 1  
HOLE OPPORTUNITIES: PHASE 1  
OPPORTUNITIES & CONSTRAINTS:  
PHASE 2  
HOLE OPPORTUNITIES: PHASE 2  
DISC FLIGHT ANALYSIS

## PART 03

Pg. 48-59

### ESSENTIALS

TEE LAYOUT  
TEE CONSTRUCTION  
BASKET DETAILS  
BASKET PLACEMENT  
STANDARDS  
CREATIVE BASKET  
PLACEMENTS  
STANDARD SIGNAGE  
SITE SPECIFIC SIGNAGE  
RECYCLING: LEARNING  
FROM GOLDEN GATE  
X STEP  
BACKHAND THROW

## PART 04

Pg. 60-76

### DESIGN

HOLE ATTRIBUTES KEY  
HOLE INDEX  
MASTER PLAN OVERVIEW  
MASTER PLAN PHASE 1  
MASTER PLAN PHASE 2  
HOLE DESIGN  
LAST THOUGHTS  
WORKS CITED

# ILLUSTRATION INDEX

---

## **PART 01**

**Figure 1.** Golden Gate Park: Teeing Off

**Figure 2.** Father of Disc Golf is Watching

<http://www.discgolf.com/disc-golf-history/>

**Figure 3.** Oak Grove County Park Sign

<http://www.discgolf.com/disc-golf-history/>

**Figure 4.** One of the First Target Holes

<http://www.discgolf.com/disc-golf-history/>

**Figure 5.** Men Teeing Off at the Beach

<http://www.dgcoursereview.com/browse.php>

**Figure 6.** Hole, Tee, and Sign Cost

**Figure 7.** Disc Golf Volunteers

<http://www.dgcoursereview.com/browse.php>

**Figure 8.** Infographic Benefits

**Figure 9.** Infographic: Age Groups

**Figure 10.** Infographic: Gender

**Figure 11.** Infographic: Education

**Figure 12.** Infographic: Official Members

**Figure 13.** Infographic: Professional Events

**Figure 14.** Infographic: Disc Golf Courses

**Figure 15.** Infographic: Course Growth

<http://www.pdga.com>

**Figure 16.** Resting Area at Shady Oaks Course

**Figure 17.** Hole 1 at Shady Oaks Course

**Figure 18.** Course Map at Shady Oaks

<http://www.dgcoursereview.com/browse.php>

**Figure 19.** Hole 4 at Shady Oaks

**Figure 20.** Hole 3 at Shady Oaks

**Figure 21.** Hole 15 at Shady Oaks

**Figure 22.** Hole 6 at Shady Oaks

**Figure 23.** Hole 8 at Oxford Park

**Figure 24.** Hole 2 at Oxford Park

**Figure 25.** Oxford Park Course Map

<http://www.dgcoursereview.com/browse.php>

**Figure 26.** Disc Golf Course SLO

<http://www.dgcoursereview.com/browse.php>

**Figure 27.** Disc Golf Course SLO 1

**Figure 28.** Disc Golf Course SLO 2

**Figure 29.** Disc Golf Course SLO 3

**Figure 30.** Disc Golf Course SLO 4



# ILLUSTRATION INDEX

---

**Figure 31.** Auburn Disc Golf Course

*<http://www.dgcoursereview.com/browse.php>*

**Figure 32.** Hole 16 at Auburn Course

**Figure 33.** Hole 11 at Auburn Course

**Figure 34.** Hole 5 at Auburn Course

**Figure 35.** Hole 7 at Auburn Course

**Figure 36.** Hole 1 at DeLaveaga Course

**Figure 37.** DeLaveaga Course Map

*<http://www.dgcoursereview.com/browse.php>*

**Figure 38.** Hole 9 at DeLaveaga Course

**Figure 39.** Hole 27 at DeLaveaga Course

**Figure 40.** Hole 2 at DeLaveaga Course

**Figure 41.** Hole 8 at DeLaveaga Course

**Figure 42A.** Tee Sign at DeLaveaga Course

**Figure 42B.** Hole 2 Tee Sign at Golden Gate

**Figure 43.** Golden Gate Park Course Map

*<http://www.dgcoursereview.com/browse.php>*

**Figure 44.** Mandatory Hole at Golden Gate

**Figure 45.** Path Crosses Fairway Sign

**Figure 46.** Natural Sitting at Golden Gate

**Figure 47.** Do Not Litter Sign at Golden Gate

## **PART 02**

**Figure 48.** Me at Golden Gate Course

**Figure 49.** UC Davis Arboretum Context Map

**Figure 50.** Arboretum: District 1 Site Analysis

**Figure 51.** Arboretum: District 2 Site Analysis

**Figure 52.** Arboretum: District 3 Site Analysis

**Figure 53.** District 3: O&C District 3

**Figure 54.** Hole 1: Tee Pad Opportunity

**Figure 55.** Hole 1: Pin 1 Opportunity

**Figure 56.** Hole 1: Pin 2 Opportunity

**Figure 57.** Hole 3: Tee Pad Opportunity

**Figure 58.** Hole 3: Pin 1 Opportunity

**Figure 59.** Hole 3: Pin 2 Opportunity

**Figure 60.** Hole 7: Tee Pad Opportunity

**Figure 61.** Hole 7: Pin 1 Opportunity

**Figure 62.** Hole 7: Pin 2 Opportunity

**Figure 63.** District 3: O&C Phase 2

**Figure 64.** Hole 11: Tee Pad Opportunity

# ILLUSTRATION INDEX

---

**Figure 65.** Hole 11: Pin 1 Opportunity

**Figure 66.** Look Out Sign

**Figure 67.** Water Hazard Sign

**Figure 68.** Hole 15: Tee Pad Opportunity

**Figure 69.** Hole 15: Pin 1 Opportunity

**Figure 70.** Out of Bounds Sign

**Figure 71.** Hole 17: Tee Area Opportunity

**Figure 72.** Hole 17: Pin 1 Opportunity

**Figure 73.** Tree Protector

**Figure 74.** Disc Flight Chart

## **PART 03**

**Figure 75.** Golden Gate Course: Me Putting

**Figure 76.** 3D Tee Layout

**Figure 77.** Sitting Stump at Golden Gate

**Figure's 78-80.** Tee Pad Construction

*<http://www.innovadiscs.com/downloads/course-brochure.html>*

**Figure 81.** 2D Basket Specifications

**Figure 82.** 3D Basket Specifications

**Figure 83.** Basket Placement Standards

**Figure 84.** River Basket Placement

*<http://www.dgcoursereview.com/browse.php>*

**Figure 85.** Trunk Basket Placement

*<http://www.dgcoursereview.com/browse.php>*

**Figure 86.** Rock Basket Placement

*<http://www.dgcoursereview.com/browse.php>*

**Figure 87.** Golden Gate: Basket Placement

**Figure 88.** Houck Design Signage

*[http://www.houckdesign.com/tee\\_sign\\_gallery.html](http://www.houckdesign.com/tee_sign_gallery.html)*

**Figure 89.** Innova Tee Sign

*<http://www.innovadiscs.com/downloads/course-brochure.html>*

**Figure 90.** Houck Design: Next Tee Sign

*[http://www.houckdesign.com/tee\\_sign\\_gallery.html](http://www.houckdesign.com/tee_sign_gallery.html)*

**Figure 91.** Rules Sign

**Figure 92.** Golden Gate: Tee Sign

**Figure 93.** Golden Gate: Do Not Litter Sign

**Figure 94.** Golden Gate: Path Crosses Fairway sign

**Figure 95.** Golden Gate: Please Do Not Distrub Planted Area Sign

# ILLUSTRATION INDEX

---

**Figure 96.** Hole 14 Tee Sign

**Figure 97.** Sitting Stump SF

**Figure 98.** Tree Cover at DeLaveaga

**Figure 99.** Left Over Stumps Near UC Davis Arboretum

**Figure 100.** Safety Net at Golden Gate

**Figure 101.** X Step Demonstration

*<http://www.innovadiscs.com/downloads/course-brochure.html>*

**Figure 102.** Backhand Drive

*<http://www.innovadiscs.com/downloads/course-brochure.html>*

## **PART 04**

**Figure 103.** Golden Gate Course: Teeing Off

**Figure 104.** Hole Attributes Key

**Figure 105.** Hole Index

**Figure 106.** Master Plan: Phase 1

**Figure 107.** Master Plan: Phase 2

**Figure 108.** Hole 1: Plan View

**Figure 109.** Hole 1: Basket 1

**Figure 110.** Hole 1: Tee Pad

**Figure 111.** Hole 3: Plan View

**Figure 112.** Hole 3: Tee Pad

**Figure 113.** Hole 3: Basket 1

**Figure 114.** Hole 7: Plan View

**Figure 115.** Hole 7: Basket 1

**Figure 116.** Hole 7: Section

**Figure 117.** Hole 8: Perspective

**Figure 118.** Hole 9: Perspective

**Figure 119.** Hole 11: Plan View

**Figure 120.** Hole 11: Basket 1

**Figure 121.** Hole 11: Section

**Figure 122.** Hole 15: Plan View

**Figure 123.** Hole 15: Tee Pad

**Figure 124.** Hole 15: Section

**Figure 125.** Hole 17: Plan View

**Figure 126.** Hole 17: Basket 1

**Figure 127.** Hole 17: Tee Pad

# PART 01



Figure 1. Golden Gate Park: Teeing off

# HISTORY OF DISC GOLF

The early history of disc golf is closely tied to the somewhat mysterious history of the recreational flying Frisbee and may have been invented in the early 1900's, but it is not known for sure. Disc golf as it is known today officially began with Ed Headrick, the father of disc golf and modern day disc sports. According to the Disc Golf Association's official website, Headrick founded the International Frisbee Association (IFA), in 1975 (Palmeri, 2008). He founded the Disc Golf Association (DGA) with the intention to create a new international sport and to promote the installation and use of disc golf courses around the world. The first formal disc golf course was designed and installed in 1975 in Oak Grove Park (Pasadena, California). Today, disc golf is one of the fastest growing sports in the United States (Rothstein, 1996). There are over 3,000 formal courses in the U.S. and many others around the world (Palmeri, 2008).



Figure 2. Father of Disc Golf Is Watching

It is important to note that modern day disc golf has not always been played with baskets as targets. The early Frisbee golf courses were played with what is called “object courses”, meaning they used anything from trees, trashcans, light poles, chicken wire baskets, and fire hydrant as targets. The game of disc golf was finally formalized when Headrick invented and patented the first Disc Golf Pole, consisting of ten chains hanging in a parabolic shape over an upward opening basket. (See figure 2)



Figure 3. Oak Grove County Park Sign



Figure 4. One of the First Target Holes

## DISC GOLF DESCRIPTION

The sport of disc golf is played much like traditional ball golf. Instead of using balls and clubs, players use discs and metal baskets. A golf disc is thrown from a tee pad, typically constructed from poured concrete (See part 3), to a target which is the hole. As a player progresses through the course, he or she must throw from where their previous shot landed. The trees, shrubs, and elevations changes located throughout the course provide challenging obstacles for the player. The hole is completed when the disc lands in the basket. Some courses, depending on their acreage size, might have par 3,4, or 5 holes. This means that

a player has either 3, 4 or 5 opportunities to finish the hole before getting a stroke against their score. “ Disc golf shares some of the same joys and frustrations of traditional golf, whether it's sinking a long putt or hitting a tree halfway down a fairway” (Palmeri, 2008).



Figure 5. Men Teeing off at the Beach

# FEASIBILITY

Apart from multiple benefits, disc golf has different economical advantages in regards to how much it actually costs to establish a course as well as the potential it has, once established, to bring in revenue. “busy courses with on-site concession facilities can enjoy annual sales of over \$50,000 from golf discs and accessories alone.”(Simmons, 2013). Another appealing aspect of the sport is that it is extremely affordable. Discs cost anywhere from \$8-\$15 and in some cases dedicated players are willing to give up extra discs they may not use. “Our survey indicated the cost to

develop a course averaged under \$8,000, with some courses costing nothing to create” (Siniscalchi, 2004). In terms of maintenance costs to upkeep any given course, they take care of themselves in most cases. From my experience, the disc golf community is very diligent at making sure trash gets placed where it belongs. At times, players themselves offer free services such as construction and placement of benches, signage and any other amenities the course may lack.

<b>Disc Pole Holes™</b>	
• DGA Mach V™:	\$325.00 x 18 = \$5850.00
• Locking Collar Assembly:	\$15.00 x 18 = \$270.00
• Anchor Assembly:	\$25.00 x 18 = \$450.00
• Concrete (Approx. 1 cu.ft. Per. hole):	\$4.00 x 18 = \$72.00
• <b>Total Basket Costs:</b>	<b>\$6,642.00</b>
<b>Tee Pads</b>	
(Each concrete pad is approximately 5 feet wide by 10 feet long and 4 inches thick.)	
• Concrete (Approximately 34, 60 lb. bags):	\$68.00 x 18 = \$1,224.00
• Forms:	\$12.00 x 18 = \$216.00
• <b>Total Tee Pad Costs:</b>	<b>\$1,440.00</b>
<b>Tee Signs</b>	
• Standard Tee Signs:	\$60.00 x 18 = \$1,080.00
• Concrete (Approx. 1 cu.ft. Per. hole):	\$4.00 x 18 = \$72.00
• <b>Total Tee Sign Costs:</b>	<b>\$1,152.00</b>

Figure 6. Hole, Tee, and Sign Cost: Graphic is From the DGA Course Design Brochure.



Figure 7. Disc Golf Volunteers



## DESIGN STRATEGIES

Before the process of constructing a disc golf facility can begin, it is important to keep current users in mind in order to successfully design a course. When asked what made a course successful, Jim Oates, a professional disc golf player, stated “the way it works with the community that is already there” (Oates). Other contributing factors to a well-designed course include accessibility, hole placement, layout, and signage. Ryan, a founder of the UC Santa Cruz disc golf club, said “different basket placements. Making them hard one week and easy others” (Ryan) make for a good course. A great course will do more than just provide fun game play. It will benefit players, the environment, and other members of the community that may not play but still use the park for other recreational activities

One important aspect of good course design is the ability to respect the existing elements and constraints that may be related to it. Planning a good course can be challenging because factors like safety, fairness, variety, and in this case sensitive areas such as botanical gardens must be taken in consideration. According to the Innova Disc Golf website, a well-designed course will lower the risk of injury for disc golf players and any other kind of visitors (Simons, 2013). This could be accomplished by making sure holes are placed away from active areas along with proper signage. In terms of variety and balance, a course should always provide a wide variety of shot choices to avoid certain natural elements, to negotiate terrain challenges while making players go up, down and across topography.

## BENEFITS OF DISC GOLF

Over the past decade there has been an increase in population to non-metropolitan areas in the U.S., which has changed the character of rural communities (Siniscalchi, 2004). Parks and Recreation specialists have the challenging task of providing equal and high quality recreational opportunities that allow for anyone regardless of age or gender to participate. It has been determined by the Professional Disc Golf Association (DGA), that people are playing the sport more than ever but the question remains, “Why?”

According to Jason Siniscalchi, Disc Golf is more than just a game (Siniscalchi, 2004). To begin with, the cost to establish a course is minimal compared to any other sport and it's free for anyone who wishes to engage in the sport. It provides a safe means of exercise for all age

groups. It helps reduce mental fatigue and encourages mental stimulation in negotiating obstacles. It highlights existing natural features throughout the park with little to no impact to the immediate environment. Depending on location of course, it can help reduce illegal activity. Schools all over the country are incorporating the sport into the curricula for physics, physical fitness, ecology, planning, and other disciplines. Organizations such as Educational Disc Golf Experience (EDGE), are providing educational programs to schools, that teach youth the basic skills of disc golf (citation). Families and friends can share quality time together. Lastly, formal and informal tournaments can bring community members together.

# WHY PLAY DISC GOLF?

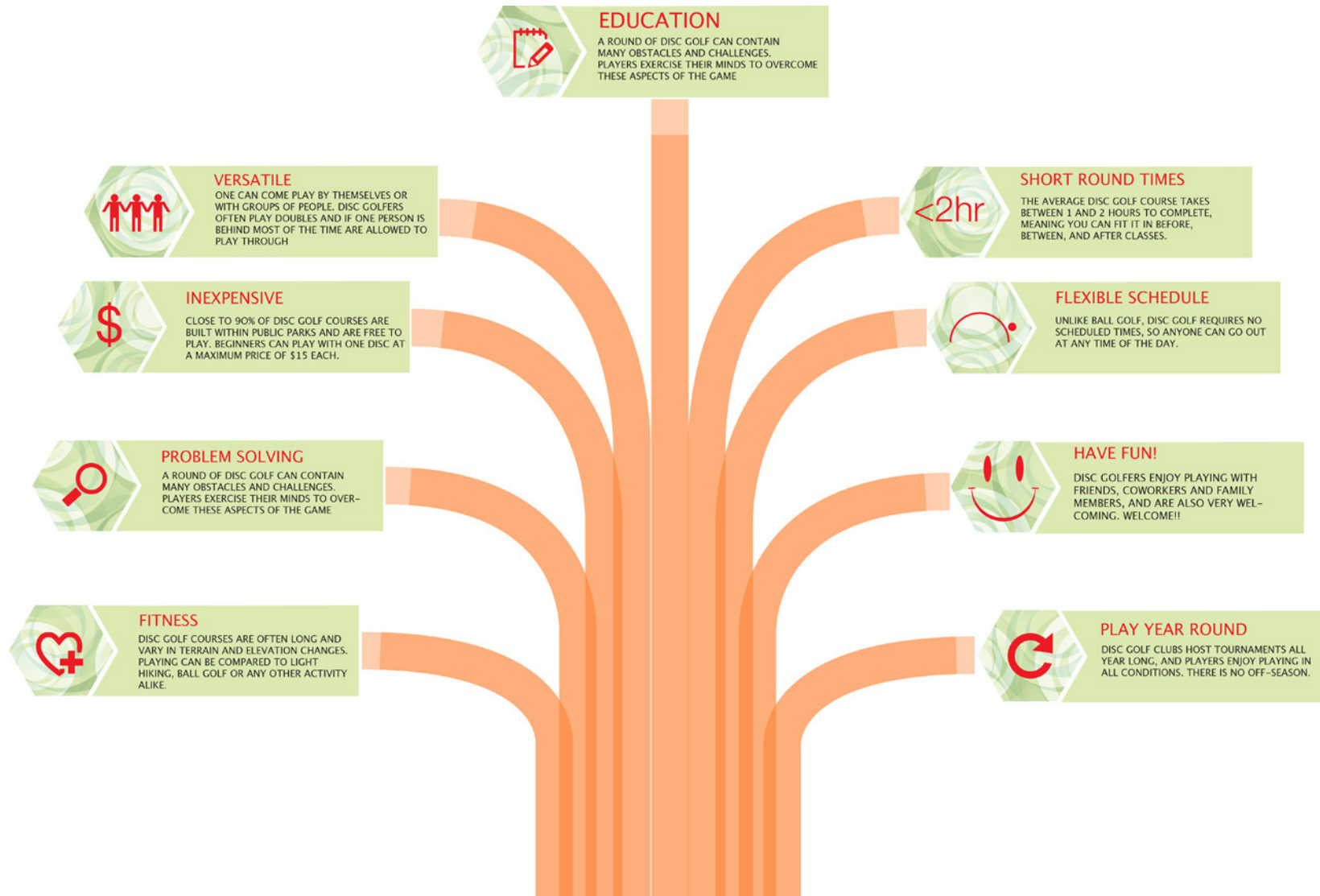

Figure 8. Infographic: Benefits

# WHO PLAYS DISC GOLF?

## BY EDUCATION

### BY AGE GROUPS

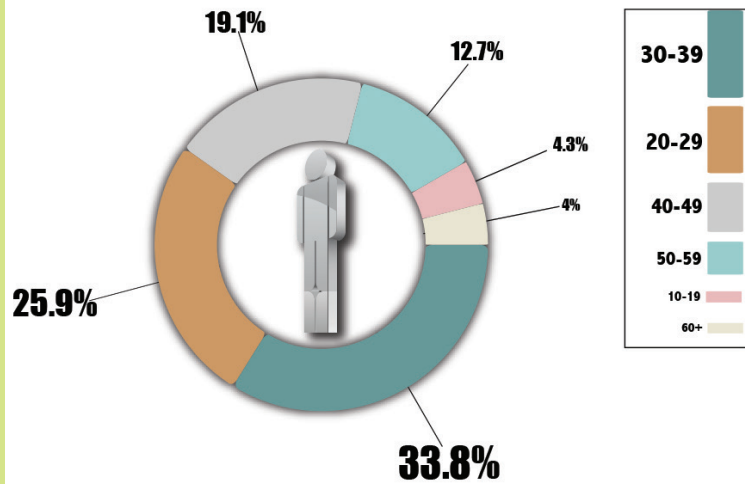

Figure 9. Infographic: Age Groups

### BY GENDER

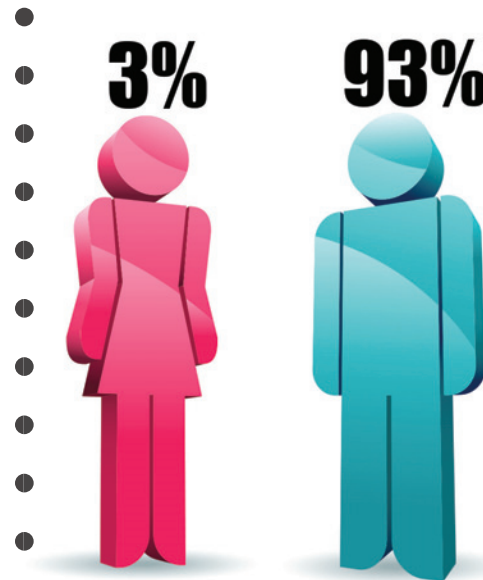

Figure 10. Infographic: Gender

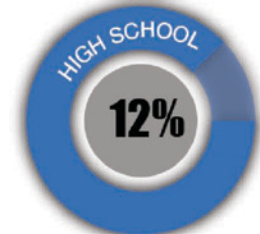
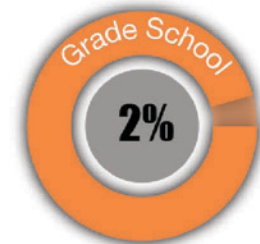
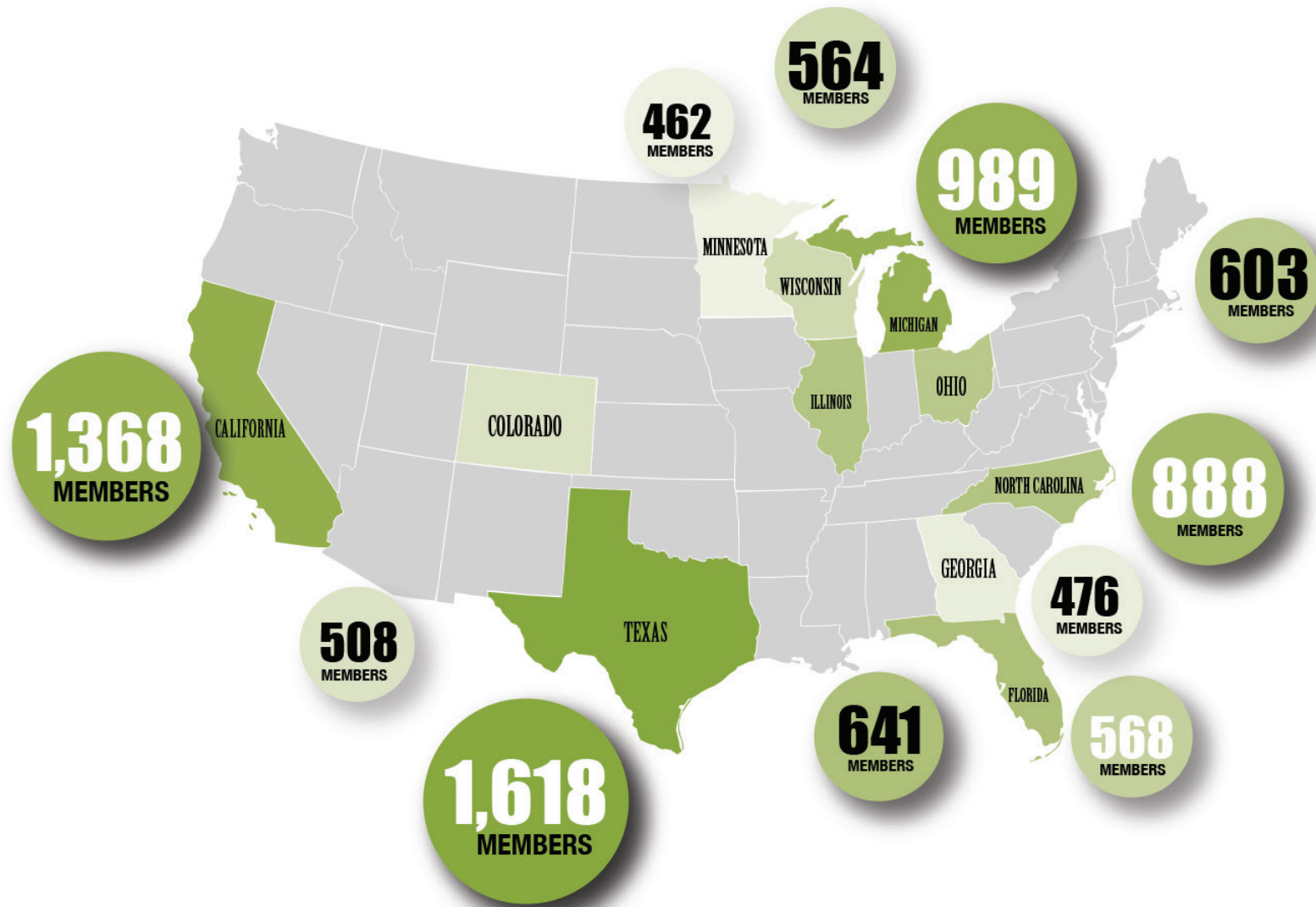

Figure 11. Infographic: Education

ALL STATISTICAL DATA WAS BORROWED FROM THE SPORT DEMOGRAPHICS SECTION ON THE PDGA WEBSITE

# WHO PLAYS DISC GOLF?



RESEARCH

Figure 12. Shows the number of official members residing on the top ten leading states in the U.S. all the way up to the year of 2012. Statistical data was obtained from the PDGA website.

# WHO PLAYS DISC GOLF?

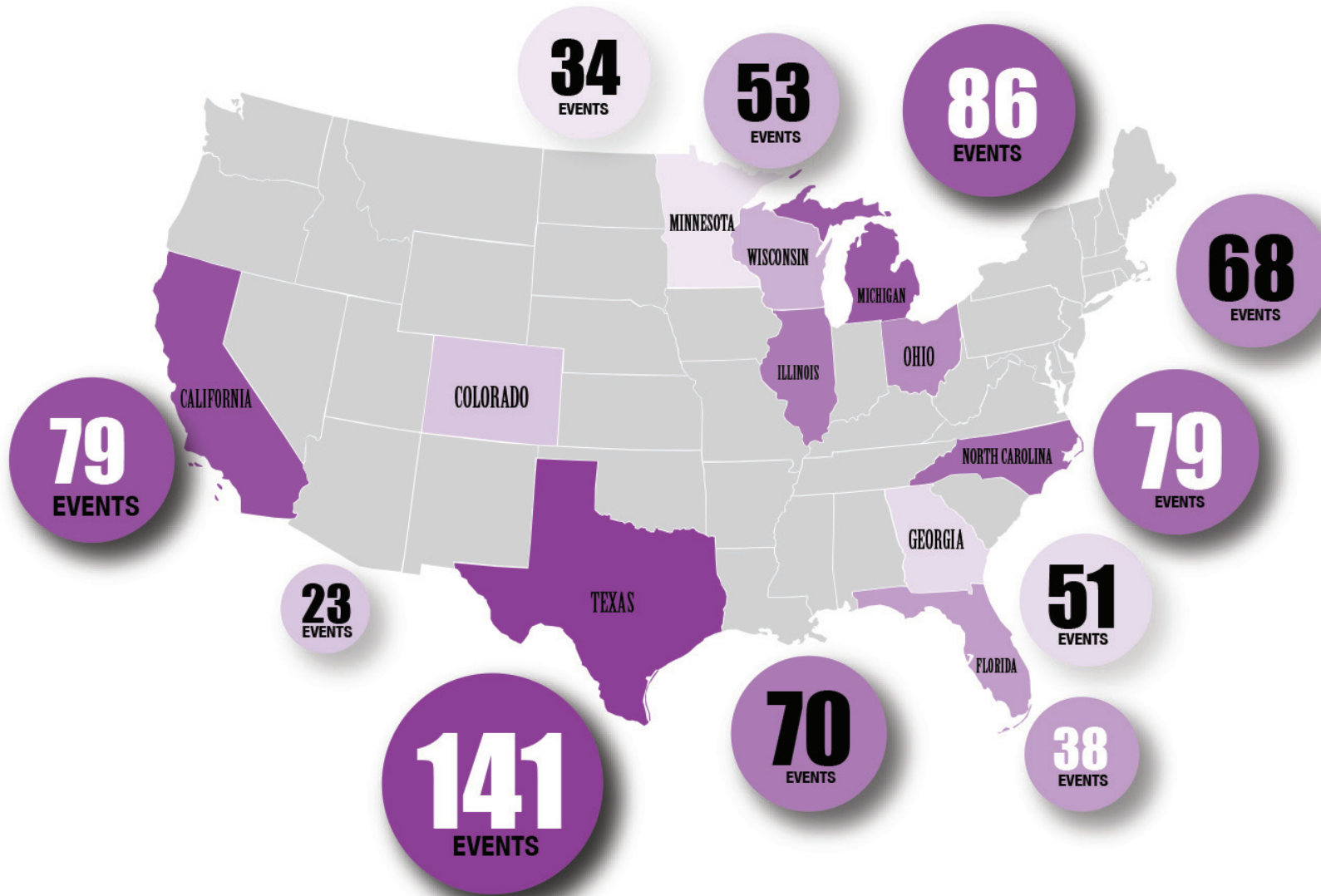

Figure 13. Shows the number of professional events played on the top ten states in the United States all the way up to the year of 2012. Statistical data was obtained from the PDGA website.

# WHERE TO PLAY DISC GOLF?

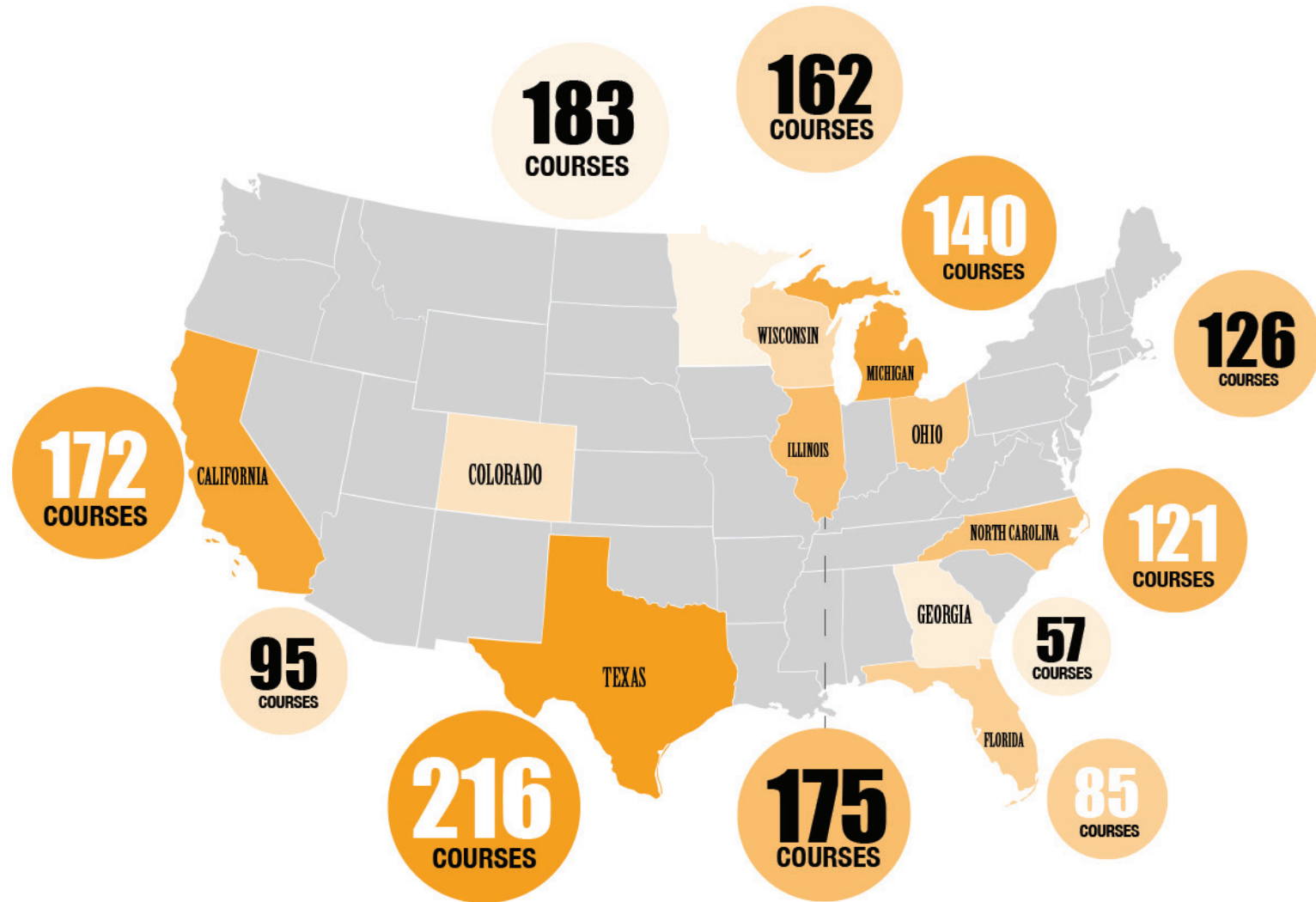
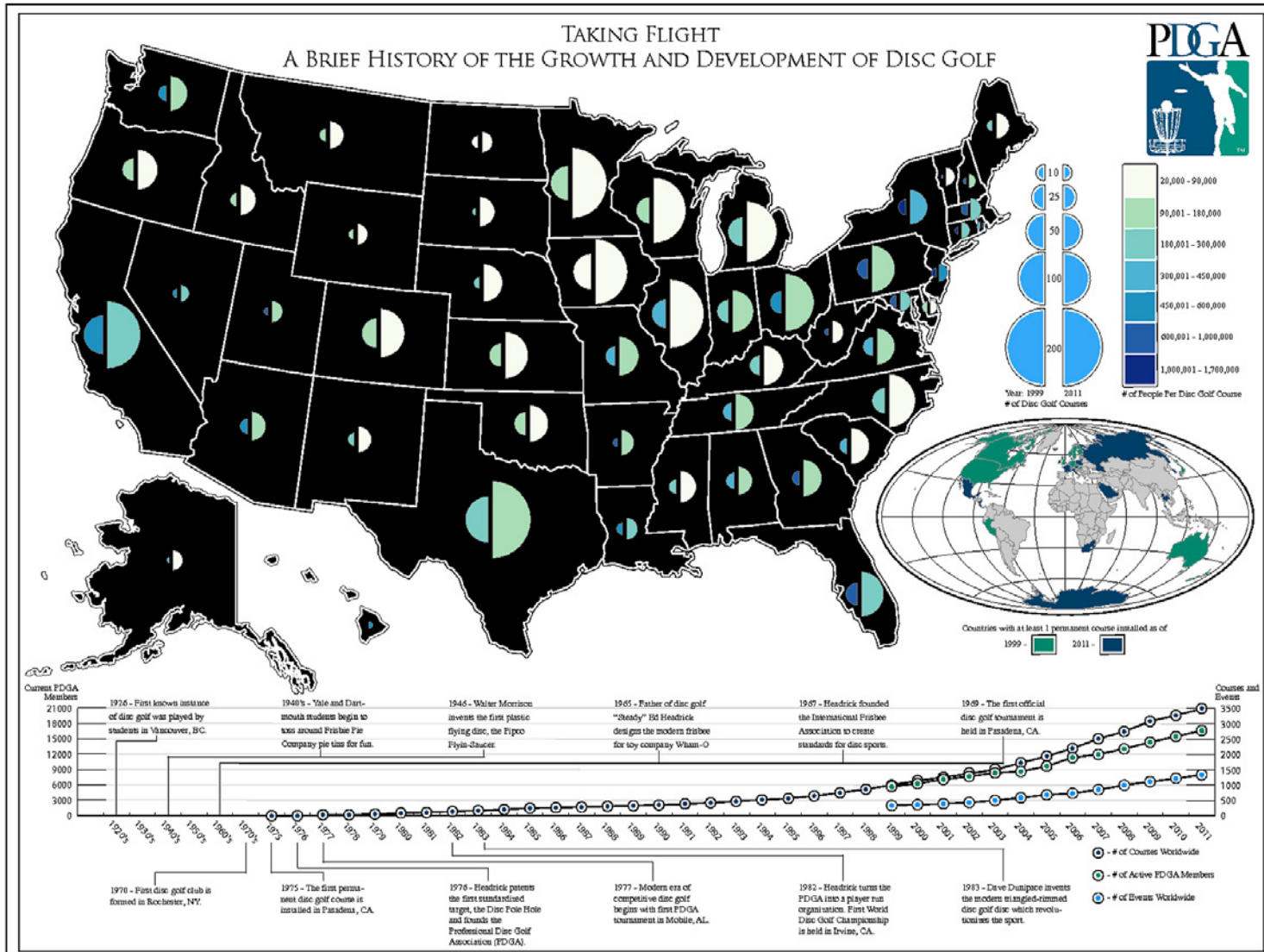

Figure 14. Shows the number of official courses located on the top ten leading states in the U.S. all the way up to the year of 2012. Statistical data was obtained from the PDGA website.

# DISC GOLF GROWTH



Main Map Projection: Albers Equal Area Conic  
 Inset Map Projection: Mercator  
 Designed By: Ian Schelby  
 Data Source: Biri Data Bank, PD-GA.com, Census.gov

Figure 15. Infographic: Course Growth



# SHADY OAKS: ORANGEVALE, CA

In my 7-8 years of experience in playing the sport, I have visited a variety of courses throughout California. In doing, so I could not help but notice the different natural elements that have the potential to make a course great or a complete failure. One of the first courses I played is located in Orangevale, California at a local city park. This course has a considerate amount of topographic changes that make it both challenging and interactive. There is a significant amount of tree canopy that helps mitigate the difficulty level of play throughout each hole and also provides shade during the hot summer days. Some trees minimize the window in which you can throw making it more difficult. Others that are in a Allee type arrangement define the flight path of discs. About five of the holes are placed along side a creek that is full for part of year. This makes the course aesthetically pleasing while also making players

select their strategy when approaching each hole. At times it can get windy, which makes holes that aren't covered by a significant amount of canopy, difficult to approach due to the tendency for discs to loose control of their natural flightpath.



Figure 16. Resting area at Shady Oaks course in Orangevale, CA



Figure 17. Hole 1 at Shady Oaks course in Orangevale, CA

# ORANGEVALE DISC GOLF COURSE MAP



18 Holes  
Par 3

Figure 18. Course Map at Shady Oaks course in Orangevale, CA

# SHADY OAKS: ORANGEVALE, CA



Figure 19. Hole 4 at Shady Oaks



Figure 20. Hole 3 at Shady Oaks CA



Figure 21. Hole 15 at Shady Oaks



Figure 22. Hole 6 at Shady Oaks

## OXFORD PARK: DAVIS, CALIFORNIA

Another course that I am familiar with is located here in Davis, California, next to Cuarto dorms in Oxford Park. This course stands out immediately because of its lack of consideration for non-disc golf player's safety. It is placed in the middle of a small park that contains picnic areas, a kids playground and parking. There is no room for error and the course lacks flexibility in terms of how many options you have to approach each hole. Another factor that makes this course unsuccessful is signage. When you get there, no sense of direction is provided as to where it begins or where it ends, not to mention the signs that are present are faded making them unreadable.



Figure 23. Hole 8 at Oxford Park



Figure 24. Hole 2 at Oxford Park

# OXFORD PARK COURSE MAP



Figure 25. Oxford Park Disc Golf Course

9 Holes  
Par 3

RESEARCH

# SAN LUIS OBISPO, CALIFORNIA

During my stay in San Luis Obispo, I played one of two courses in the area. On this particular course, wind played an important role on how successfully the course could be completed. It offered little change in topography and was very open with little to no tree canopy. I visited the park about a dozen times throughout a year and, for the most part, it was always windy. This made the course extremely frustrating to play because no matter how good one threw, the flight of the disc was unpredictable. Another discouraging element in this course was the tall grasses that were not maintained. As a result, it was hard, and at times impossible, to find your

disc. Overall, this course has potential to be a good course if visited during times of no wind.



Figure 26 Disc Golf Course SLO

# SAN LUIS OBISPO, CALIFORNIA



Figure 27. Disc Golf Course SLO 1



Figure 28. Disc Golf Course SLO 2

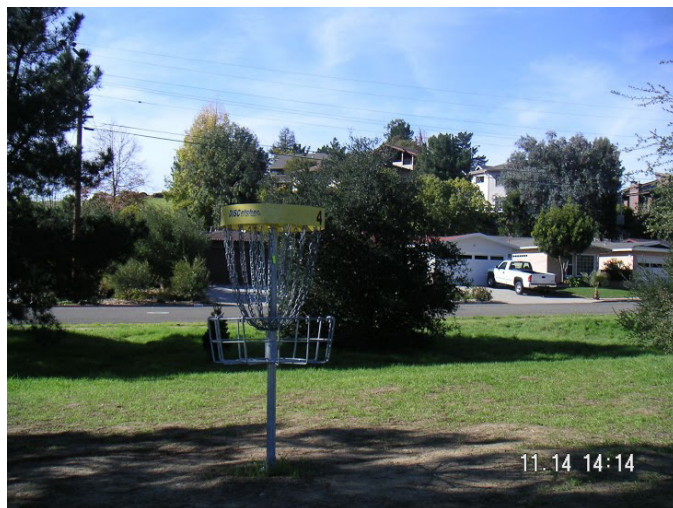

Figure 29. Disc Golf Course SLO 3

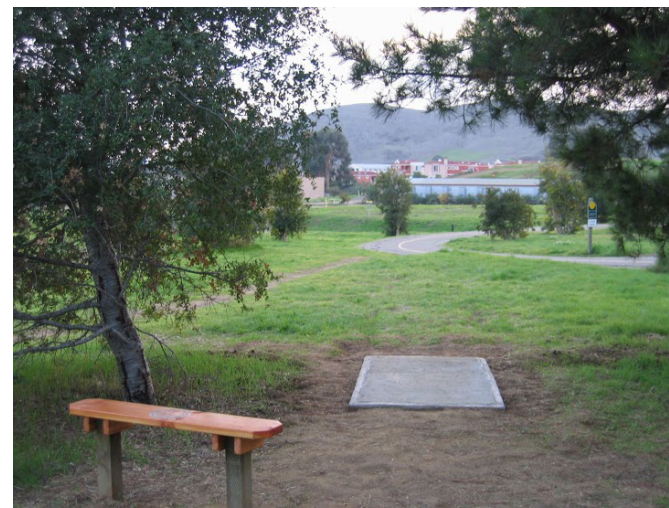

Figure 30 Disc Golf Course SLOz 4

# AUBURN, CALIFORNIA

This course is located a couple hours up I-80 near Grass Valley CA and is integrated into a significantly big park that contains picnic areas, a creek, tennis courts, a man made pond, a trail system, parking and a kids play-ground. Although this course lacks significant elevation changes, it makes up for it in aesthetics and shots that range in difficulty level. Some of the holes are located next to the man made pond and can work against you or to your favor depending of what kind of shot you have. At times discs do, go into the water and are basically lost unless one is willing to jump into the pond to search for it. This kind of scenario pushes the player to play with strategy, a great quality to have in each and every hole. Apart from game play, this course offers a great opportunity for exercise. Some holes are downhill and others

uphill, other holes are located within a landscape that contains rocks of all sizes making the user have to climb or jump in order to reach the hole.

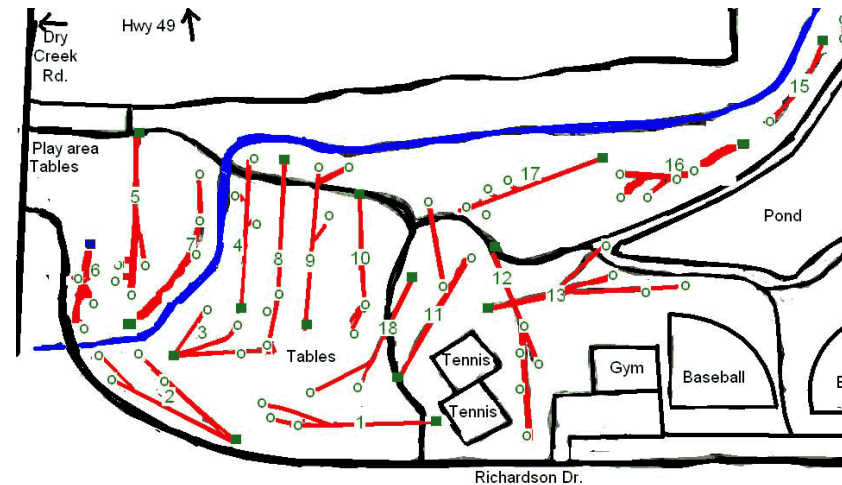

Figure 31. Auburn Disc Golf Course

18  
Holes



# AUBURN, CALIFORNIA

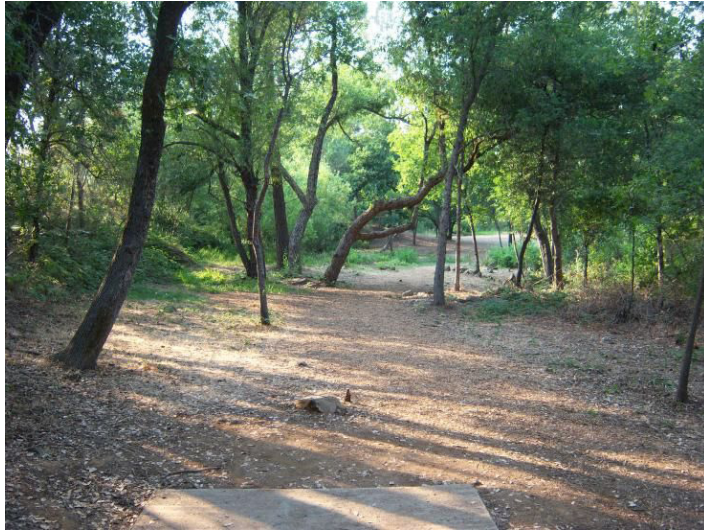

Figure 32. Hole 16 at Auburn disc golf course.



Figure 33. Hole 11 at Auburn disc golf course.



Figure 34. Hole 5 at Auburn disc golf course.



Figure 35. Hole 7 at Auburn disc golf course.

## DE LAVEAGA: SANTA CRUZ, CALIFORNIA

Located near a local Golf Course in Santa Cruz California, this course offers the most topographic changes and most holes (29) than any of the visited courses (see figure). This course contains a mixture of many varieties of native and non native plants and trees that make up the backbone of many of the holes. This allows for a range of shots, long, up, down, through trees (see figures 38-41). This encourages players to choose different routs and different types of discs. This course also offers a variety of playing hazards such as steep slopes, high levels of vegetation, and elevation changes. These play an important role how the game is played. Visually, this course provides a variety of signage to help users

navigate the course easily and to help understand the rules, etiquette and location of each and every hole.



Figure 36. Hole 1 at Delaveaga Course

# DE LAVEAGA: SANTA CRUZ, CALIFORNIA

27 Holes  
Par 3

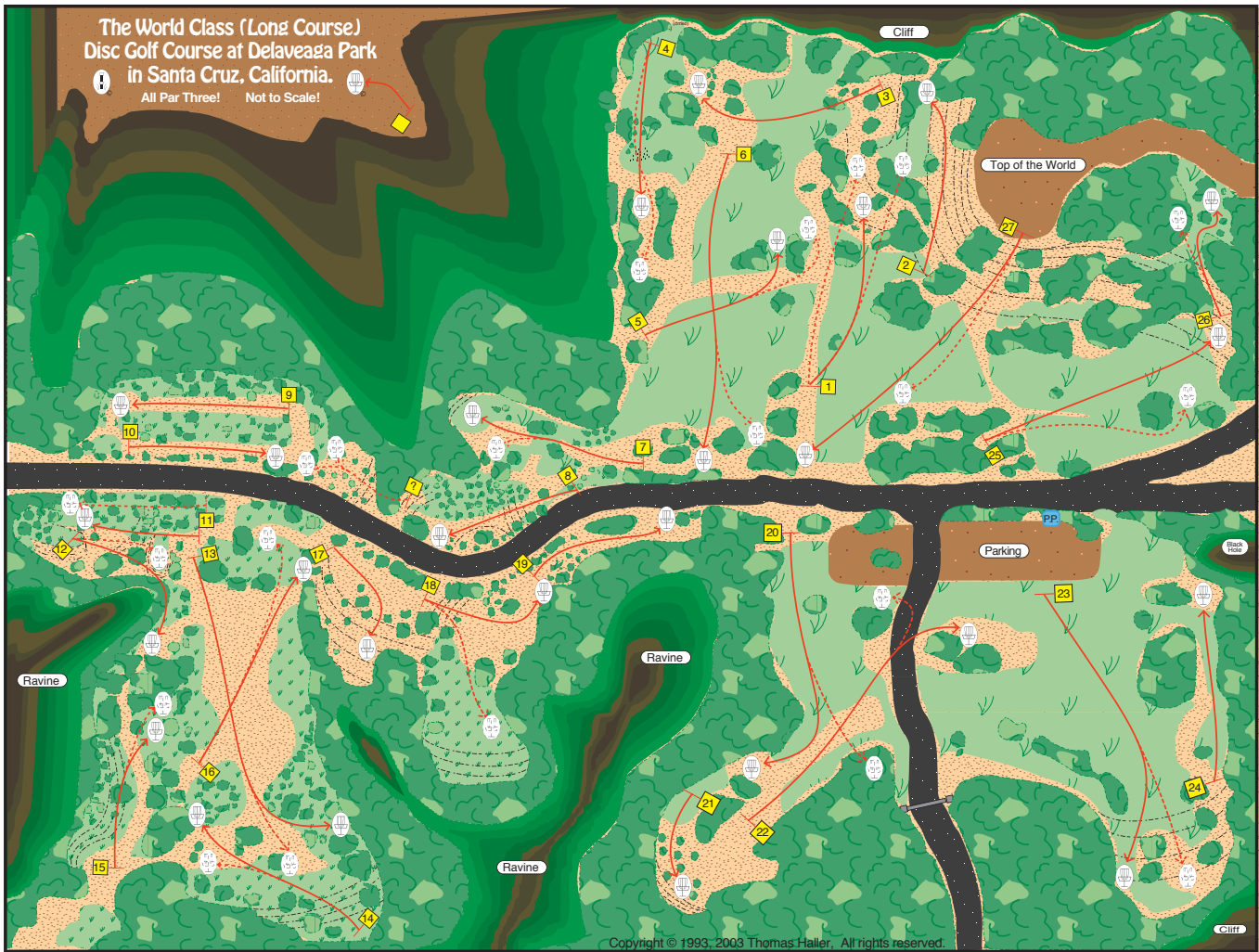

Figure 37. DeLaveaga Course Map.

RESEARCH

# DE LAVEAGA: SANTA CRUZ, CALIFORNIA



Figure 38. Hole 9 at DeLaveaga Course



Figure 39. Hole 27 at DeLaveaga Course.



Figure 40. Hole 2 at DeLaveaga Course.



Figure 41. Hole 8 at DeLaveaga Course



Figure 42. Tee Sign at DeLaveaga Course

# GOLDEN GATE PARK: SAN FRANCISCO, CA

This eighteen-hole course is located within the Golden State Park in San Francisco, California. This course offers a decent amount of topographic changes. Sometimes you are shooting up, others you are shooting down. The amount of tree canopy present is just the right amount to make it challenging while also making it aesthetically pleasing (see figure 44). The signage provided at this course is probably by far one of the best I encountered throughout my visits to other courses. Signs are well maintained which makes them easy to follow not to mention you always know where to go even if it's your first time. Although not all, some of the basket placements at this course are fun and challenging. They are mounted in either man made structures that elevate them higher than

ground level, or in structures made out of stumps of wood. It seemed that they utilized existing left over stumps and re-used them for sitting, baskets placement structures and signage. The only downside to this course, was that it was constantly windy which due to the coastal weather. Overall, I found this course to be well balanced and welcoming.



Figure 42. Hole 2 Tee Sign at Golden Gate Park

# GOLDEN GATE PARK: SAN FRANCISCO, CA

18 Holes  
Par 3



HOLE	1	2	3	4	5	6	7	8	9	FRONT	10	11	12	13	14	15	16	17	18	B
PIN A PAR	239 <sup>3</sup>	185 <sup>3</sup>	311 <sup>3</sup>	243 <sup>3</sup>	303 <sup>3</sup>	271 <sup>3</sup>	285 <sup>3</sup>	283 <sup>3</sup>	205 <sup>3</sup>	2325 <sup>27</sup>	264 <sup>3</sup>	237 <sup>3</sup>	268 <sup>3</sup>	198 <sup>3</sup>	286 <sup>3</sup>	327 <sup>3</sup>	251 <sup>3</sup>	328 <sup>3</sup>	302 <sup>3</sup>	2
PIN B PAR	243 <sup>3</sup>	206 <sup>3</sup>	343 <sup>3</sup>	252 <sup>3</sup>	368 <sup>4</sup>	304 <sup>3</sup>	331 <sup>3</sup>	291 <sup>3</sup>	245 <sup>3</sup>	2568 <sup>28</sup>	298 <sup>3</sup>	295 <sup>3</sup>	264 <sup>4</sup>	229 <sup>3</sup>	286 <sup>3</sup>	383 <sup>4</sup>	274 <sup>3</sup>	357 <sup>4</sup>	391 <sup>4</sup>	2
PIN C PAR	294 <sup>3</sup>	216 <sup>3</sup>	369 <sup>4</sup>	282 <sup>3</sup>	405 <sup>4</sup>	319 <sup>3</sup>	374 <sup>4</sup>	296 <sup>3</sup>	252 <sup>3</sup>	2847 <sup>30</sup>	298 <sup>3</sup>	300 <sup>3</sup>	415 <sup>4</sup>	238 <sup>3</sup>	369 <sup>4</sup>	393 <sup>4</sup>	289 <sup>3</sup>	441 <sup>4</sup>	395 <sup>4</sup>	3

Figure 4.3. Golden Gate Park Course Map

# GOLDEN GATE PARK: SAN FRANCISCO, CA



Figure 44. Mandatory Hole at Golden Gate Park



Figure 45. Path Crosses Fairway Sign at Golden Gate Park.



Figure 46. Natural Sitting at Golden Gate Park.



Figure 47. Do not Litter Sign at Golden Gate Park.

## EDGE (EDUCATIONAL DISC GOLF EXPERIENCE)

### EDGE'S MISSION

EDGE, aims to produce and provide curricula, programs, and equipment to educators seeking to introduce the sport of disc golf to young people anywhere from sixth to twelve grade. The goal is to promote a healthy lifestyle for both kids and adults, by learning the life time sport of disc golf. This is done through carefully developed lesson plans, that not only teach disc golf but also incorporate math, physics, and the environment into it.

### MY VISION

To use EGDE as a resource to incorporate the sport of disc golf into the curriculum of physical education here at UC Davis. The proposed disc golf course would serve as an outdoor classroom for those who wish to enroll in the class. One of the main goals of the class would be to promote the sport of disc golf as a healthy alternative to conventional exercise and to remove the negative stigma disc golf has developed over the years by properly educating students about the sport.



# LEARNING OBJECTIVES

## Classroom objectives:

- Importance & benefits of disc golf
  - Basic knowledge of the sport
  - Structure of tournament play
- Basic installation of baskets & tee pads.
- Brief History of Arboretum
- Proper course etiquette specific to the Arboretum
- Importance of plant life and how it might be affected by disc golfers.

## Field Objectives:

- Putt & Approach Strategies
- The x step
- Backhand Throw
- Forehand Throw
- Tournament play

## Volunteering:

Part of the class, would encourage each student to sign up for a day of volunteering at the Arboretum. Work might be specific to the Arboretum or it could be geared towards the upkeep of the suggested course. The goal, is to help students understand the importance of community involvement as it relates to the sport of



# PART 02



Figure 48. Me at Golden Gate Course

# SITE CONTEXT

Located on the south end of the UC Davis Campus, the Arboretum is composed of a series of botanical gardens around the North Fork of Putah Creek watershed. It serves as an educational tool for different academic departments throughout the campus. Overtime, it has become a destination for the larger region. Making this iconic landscape a place with endless recreational and educational opportunities.

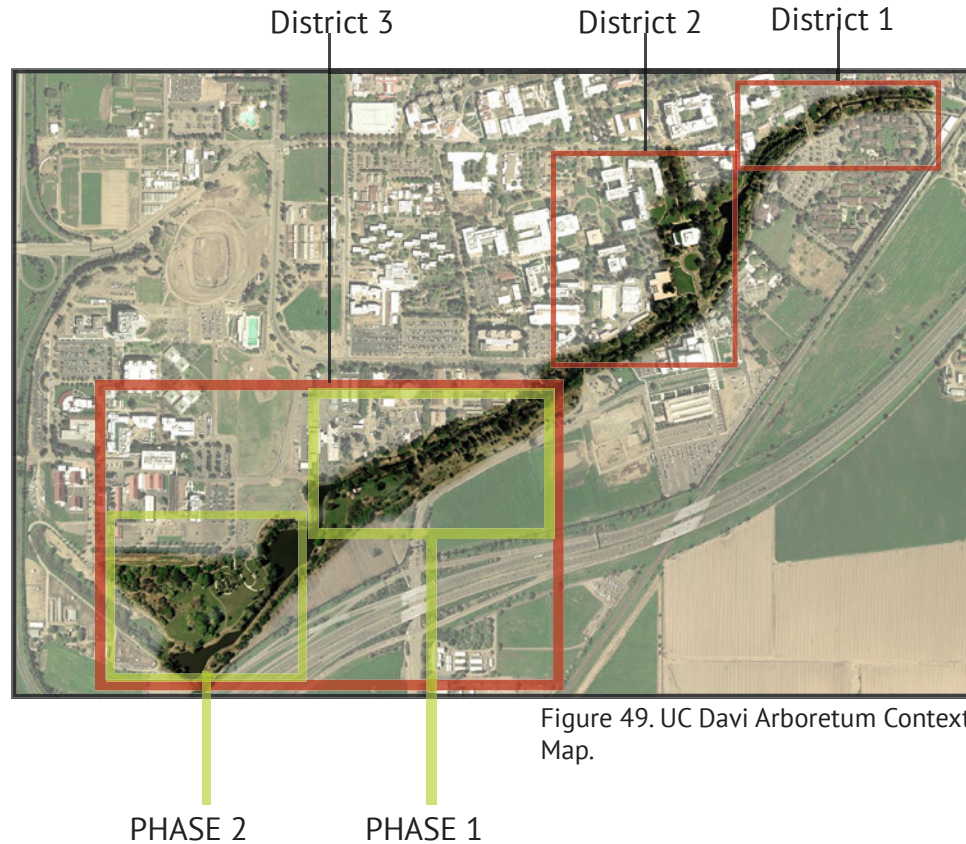

Figure 49. UC Davi Arboretum Context Map.

# SITE ANALYSIS

## PROCESS

Conducting the following site analysis of the entire Arboretum, took frequent visits in which I mapped out existing amenities that would be of value to current users and future disc golf players. Such amenities included water fountains, visitor parking, bathrooms, and sitting spaces. Once the necessary amenities were mapped out, access points from which players would access the course were located along with pedestrian pathways that would facilitate the flow of the suggested disc golf course. Areas of high pedestrian traffic and sensitive plating areas were also cataloged to gain a better understanding of areas that might be of conflict with the flight of a disc. The main goal, was to avoid any areas that might damage plant life or hurt

existing users. Elements such as wind, sun exposure, tree canopy, topography and water hazards were also noted in order to properly asses which areas provided the necessary space for a tee and a basket to be constructed.

## FINDINGS

After a careful review of the site, its constraints, and suggestions from my committee members, It was determined that districts one and two were unsuitable for the placement of a disc golf course. As a result, I had to undergo another search for any available space around the Arboretum that would allow me to design without putting the safety of pedestrians or plant life at risk. Fortunately, such area existed near the Mondavi center on the south side of the Acacia Grove and the Putah Creek lodge.

# SITE ANALYSIS: DISTRICT 1 (ELIMINATED)

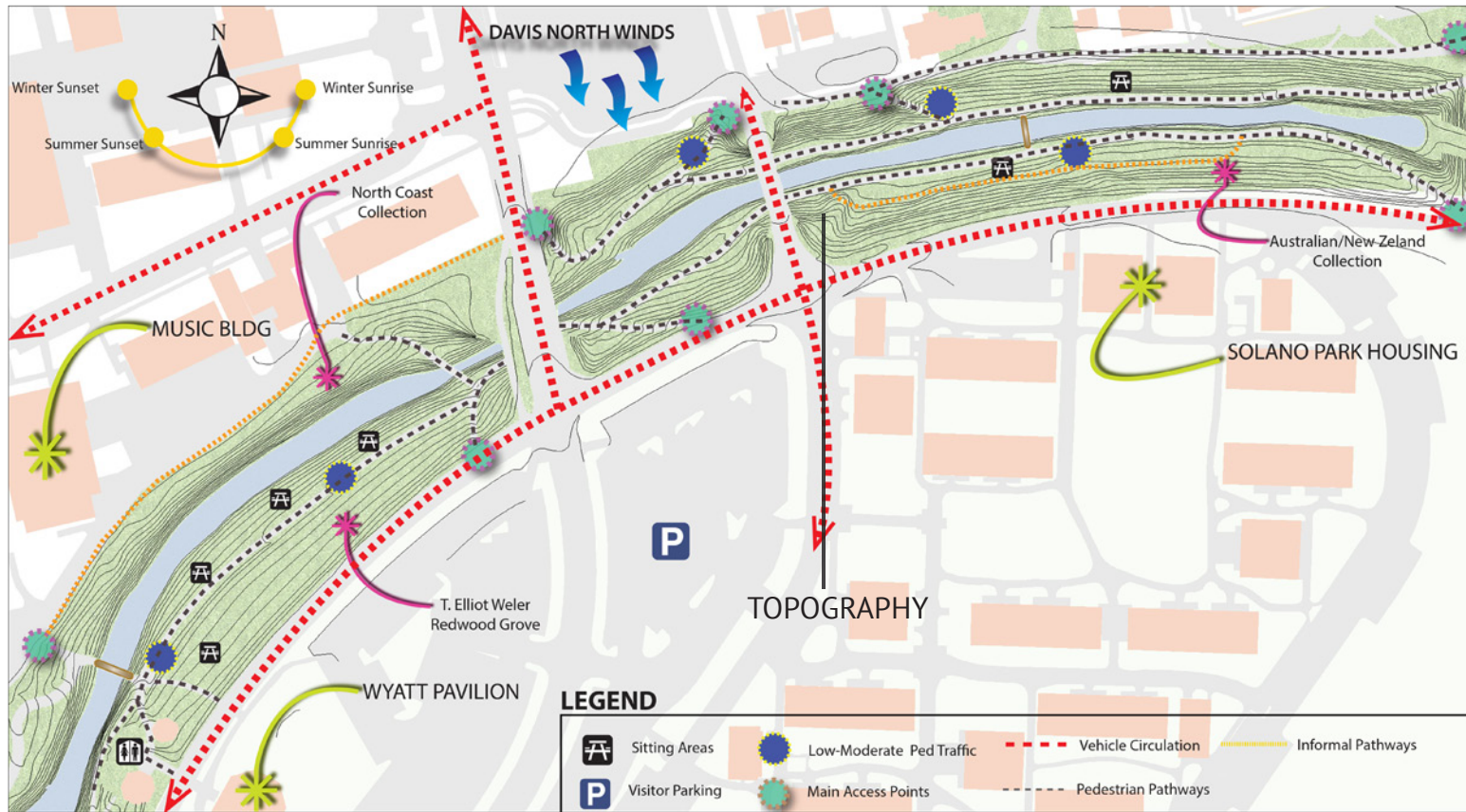

Figure 50. Arboretum: Site Analysis. This map indicates the location of significant gardens, amenities, topography lines, access points, and circulation routes.

# SITE ANALYSIS: DISTRICT 2 (ELIMINATED)

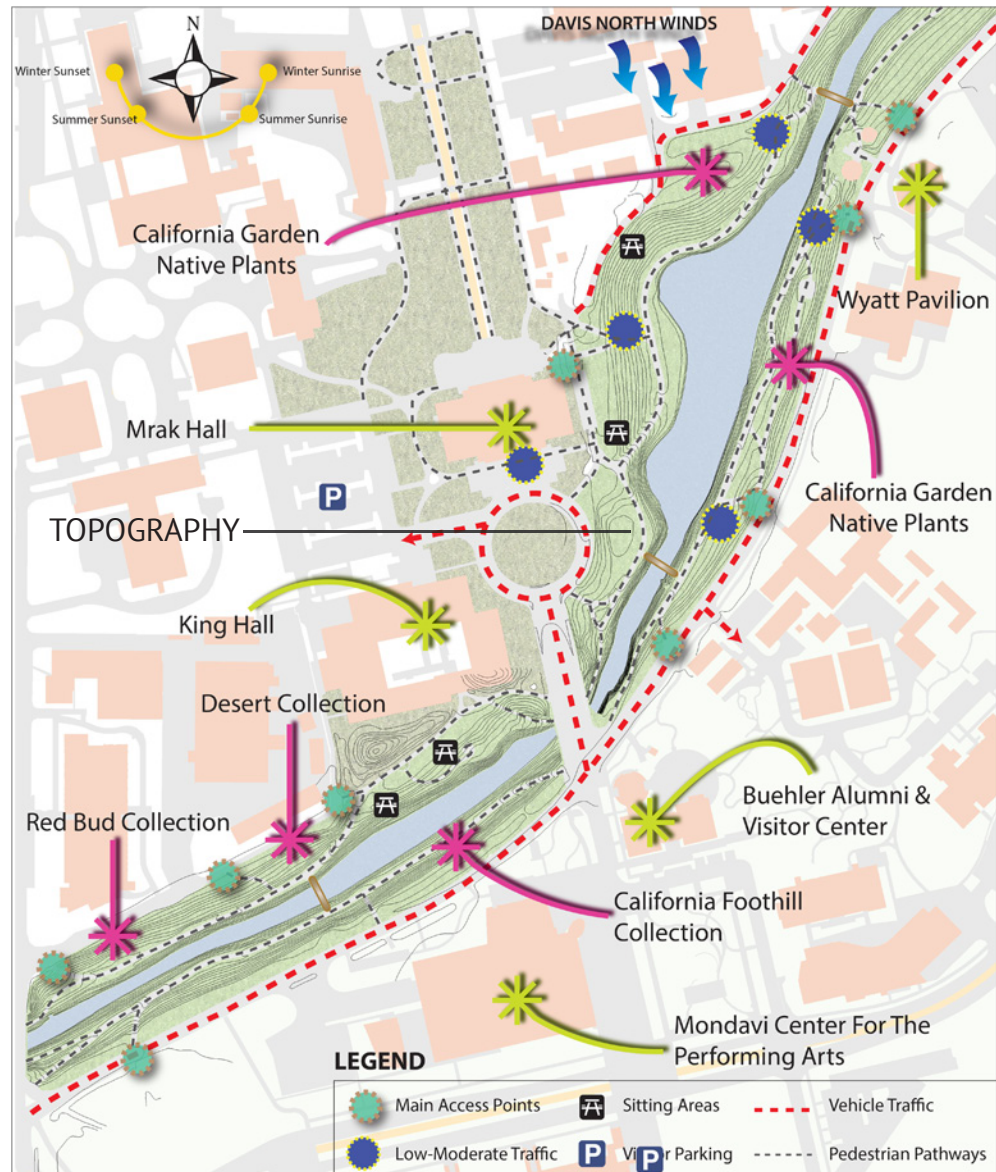

Figure 51. Arboretum: District 2 Site Analysis. This map indicates the location of significant gardens, amenities, topography lines, access points, and circulation routes.

# SITE ANALYSIS: DISTRICT

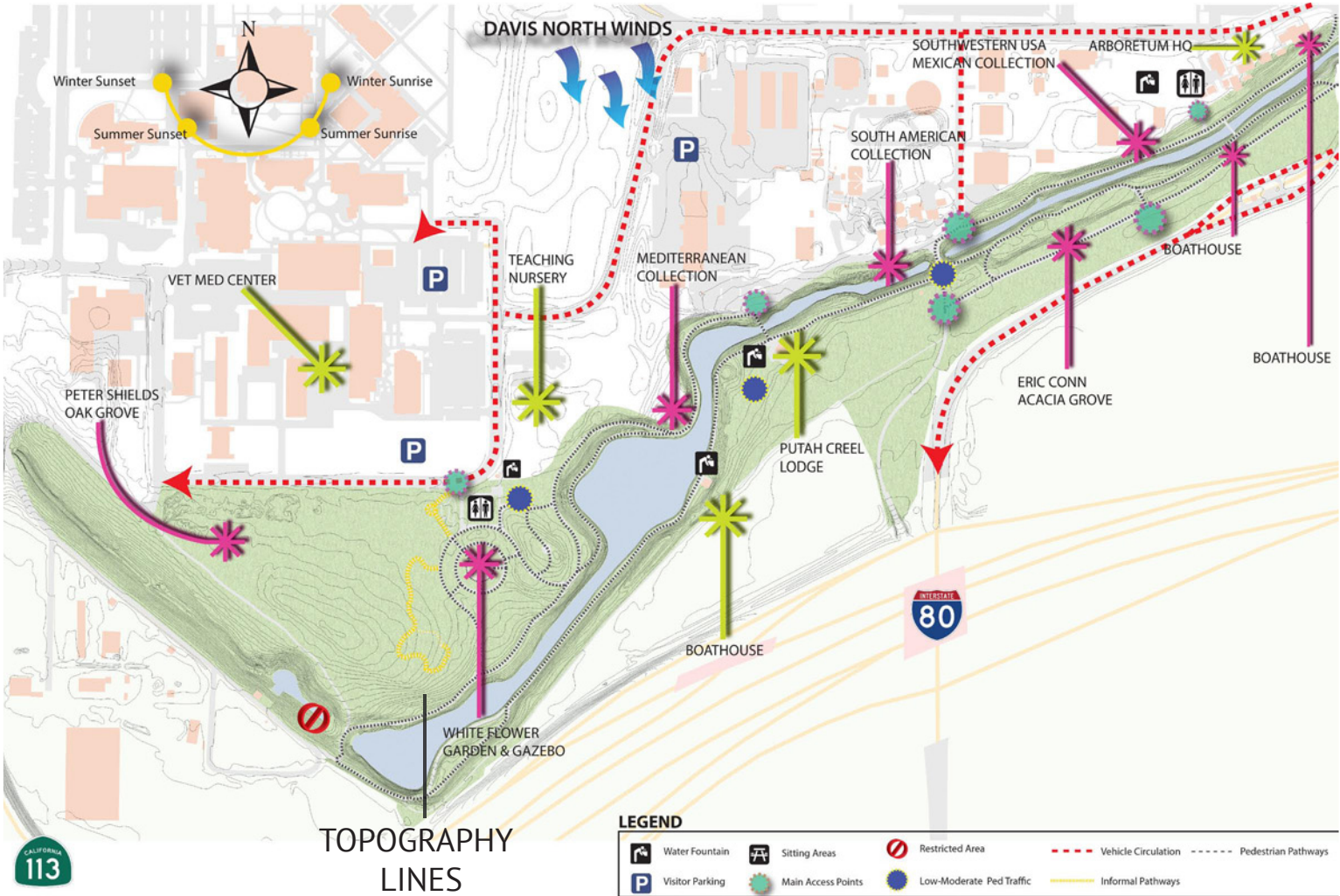

Figure 52. Arboretum: District 3 Site Analysis. This map indicates the location of significant gardens, amenities, topography lines, access points, and circulation routes.



# OPPORTUNITIES & CONSTRAINTS: PHASE 1

## Opportunities

These areas indicate the location of potential tee and hole placement locations that would have little to no impact to the existing community.

## CONSTRAINTS

The yellow areas in this map indicate areas where there is not enough space for any hole placement. They also represent existing botanical gardens that are off limits due to their educational value.

**SIDE NOTE:** Although all holes were carefully analyzed during the design process, only the holes that best highlighted existing elements such as tree canopy, elevation changes, water hazards, and wind exposure were illustrated.

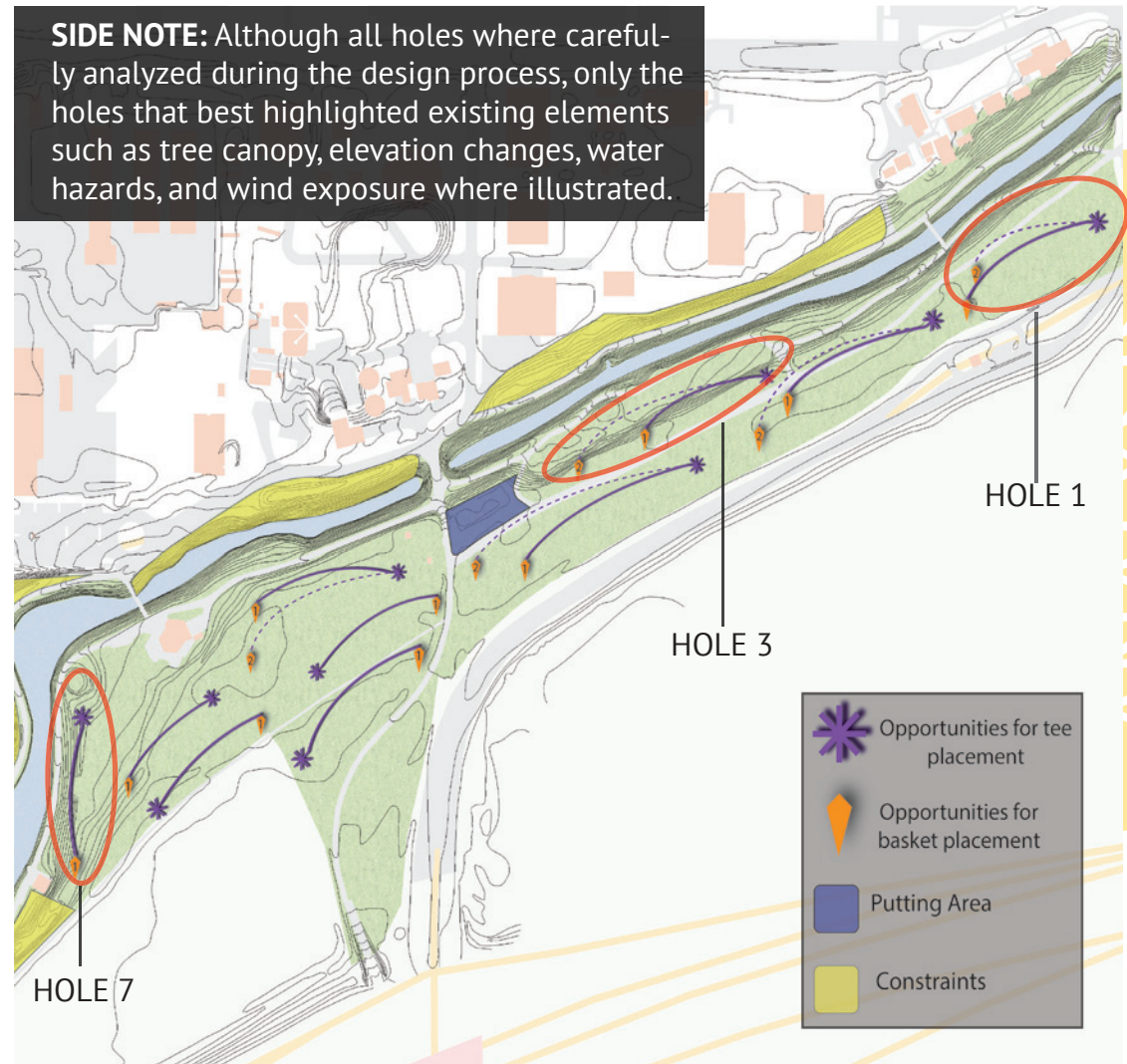

Figure 53. District 3: Opportunities & Constraints Phase 1

# HOLE LOCATION OPPORTUNITIES: HOLE 1



Figure 54. Hole 1: Tee Pad Opportunity

## SUGGESTED ADDITIONS & PURPOSE:

- BILLBOARD WITH COURSE MAP, RULES, AND TOURNAMENT ANNOUNCEMENTS- PROVIDE PLAYERS WITH PROPER INFORMATION TO NAVIGATE COURSE CORRECTLY.
- SHADE STRUCTURE FOR TEE PAD AREA-PROTECTION FROM SUN EXPOSURE DURING SUMMER DAYS
- NATURAL WATER FEATURE-INCREASE THE DIFFICULTY LEVEL BY HAVING A WATER HAZARD NEAR THE PIN PLACEMENT

## CHALLENGING ELEMENTS:

- HOLE DISTANCE
- WIND INTERFERENCE
- TREE CANOPY NEAR THE BASKET PLACEMENTS



Figure 55. Hole 1: Pin 1 Opportunity



Figure 56. Hole 1: Pin 2 Opportunity

# HOLE LOCATION OPPORTUNITIES: HOLE 3



Figure 57. Hole 3: Tee Pad Opportunity

## SUGGESTED ADDITIONS & PURPOSE:

-OUT OF BOUNDS SIGN TO KEEP DISCS FROM FLYING INTO PEDESTRIAN PATHWAY

-TREE PROTECTOR TO PREVENT DAMAGE TO BARK FROM DISC IMPACT

## CHALLENGING ELEMENTS:

-TREE CANOPY DENSITY

-HOLE DISTANCE

-PEDESTRIAN PATHWAY ON THE LEFT HAND SIDE



Figure 58. Hole 3: Pin 1 Opportunity



Figure 59. Hole 3: Pin 2 Opportunity

# HOLE LOCATION OPPORTUNITIES: HOLE 7



Figure 60. Hole 7: Tee Pad Opportunity

## SUGGESTED ADDITIONS:

- OUT OF BOUNDS SIGN TO KEEP DISCS FROM FLYING INTO PEDESTRIAN PATHWAY
- TREE PROTECTOR TO PREVENT DAMAGE TO BARK FROM DISC IMPACT

## CHALLENGING ELEMENTS:

- WIND INTERFERENCE
- ELEVATION CHANGE
- TREE CANOPY NEAR THE BASKET PLACEMENTS



Figure 61. Hole 7: Pin 2 Opportunity



Figure 62. Hole 7: Pin 1 Opportunity

# OPPORTUNITIES & CONSTRAINTS: PHASE 2



Figure 63. District 3: Opportunities & Constraints Phase 2.

# HOLE LOCATION OPPORTUNITIES: HOLE 11



Figure 64. Hole 11: Tee Pad Opportunity



Figure 65. Hole 11: Pin 1 Opportunity

## SUGGESTED ADDITIONS:

- SIGNAGE THAT ALLOWS OTHER USERS TO KNOW THAT DISCS ARE BEING THROWN.
- SOME KIND OF NET TO HELP FETCH DISCS THAT LANDED IN WATER NEAR THE BASKET.

## CHALLENGING ELEMENTS:

- WIND INTERFERENCE
- ELEVATION CHANGE
- WATER HAZARD



Figure 66. Look Out Sign



Figure 67. Water Hazard Sign

# HOLE LOCATION OPPORTUNITIES: HOLE 15



Figure 68. Hole 15: Tee Pad Opportunity

## SUGGESTED ADDITIONS:

- SIGNAGE THAT ALLOWS OTHER USERS TO KNOW DISCS ARE BEING THROWN
- OUT OF BOUNDS SIGN TO ENCOURAGE PLAYERS NOT TO LAND ON IT.

## CHALLENGING ELEMENTS:

- WIND INTERFERANCE
- ELEVATION CHANGE
- DISTANCE



Figure 69. Hole 15: Pin 1 Opportunity



Figure 70. Out of Bounds Sign.



# HOLE LOCATION OPPORTUNITIES: HOLE 17



Figure 71. Hole 17: Tee Area Opportunity

## SUGGESTED ADDITIONS:

- THIS HOLE WILL BE USING THE EXISTING HARDSCAPE AS A TEE, SO IT WILL ONLY BE NECESSARY TO SOMEHOW MARK THE DIMENSIONS OF A TYPICAL TEE. (SEE ESSENTIAL SECTION)
- TREE PROTECTORS TO PREVENT DAMAGE TO BARK FROM DISC IMPACT
- OUT OF BOUNDS SIGN TO ENCOURAGE PLAYERS FROM LANDING ON WALKWAYS.

## CHALLENGING ELEMENTS:

- ELEVATION CHANGE
- TREE CANOPY
- SOME WIND



Figure 72. Hole 17: Pin 1 Opportunity



Figure 73. Tree Protection



# DISC FLIGHT ANALYSIS

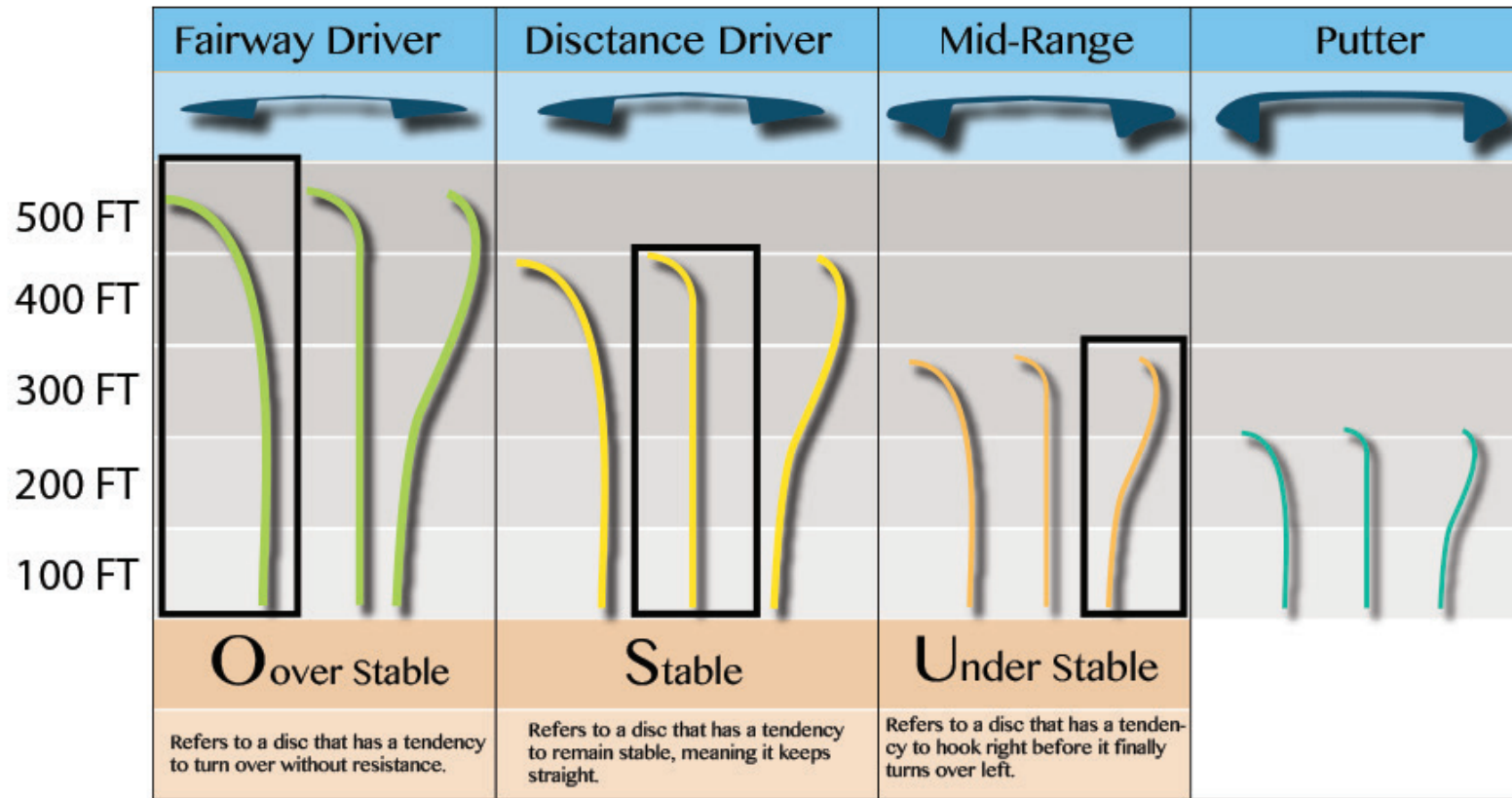

Figure 74. Disc Flight Chart

Understanding how discs fly was essential during the design stage of my project. Knowing the 3 basic types of flight discs take (Figure 74), allowed me to envision how a disc might interact with the existing natural elements at each hole. This is important because keeping a balance throughout the entire course is essential so that a player isn't throwing the same shot with the same disc every time.



PART  
03

Figure 75. Golden Gate Course: Me Putting

# TYPICAL TEE LAYOUT DIAGRAM



Figure 77. Sitting Stump at Golden Gate Course

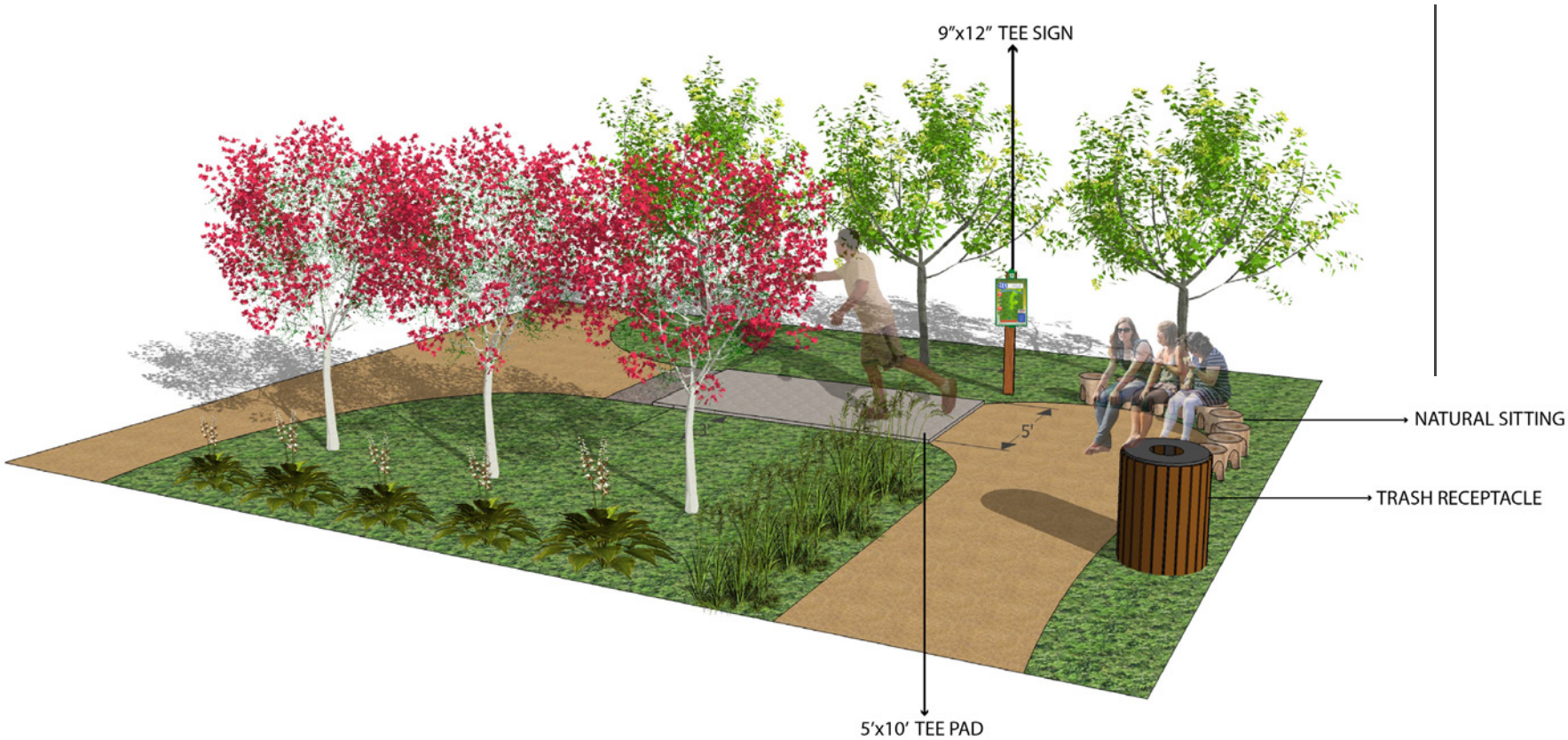

Figure 76. 3D Tee Layout

# TEE LAYOUT: CONSTRUCTION



Frame is ready for concrete.



Float the concrete to force rocks down. It will help with texturing.



Drag the texturing tool across the pad from the side.



Use wheelbarrows to transport concrete to tees in remote areas.



Once enough concrete is in the form, use 2x4 to screed, filling all areas.



A prepared gang of workers makes tee construction easy.

Figure 78-80. TEE PAD CONSTRUCTION

# BASKET SPECIFICATIONS:

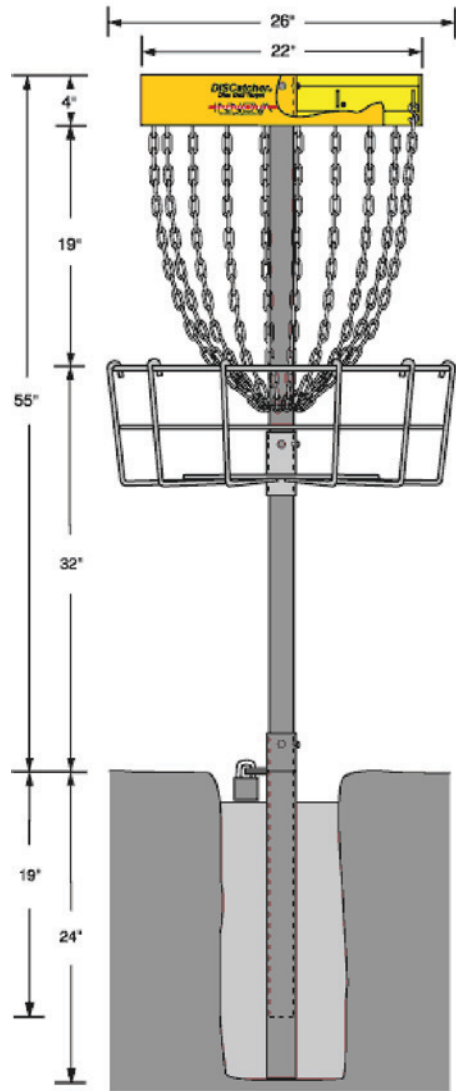

Figure 81. 2D BASKET SPECS

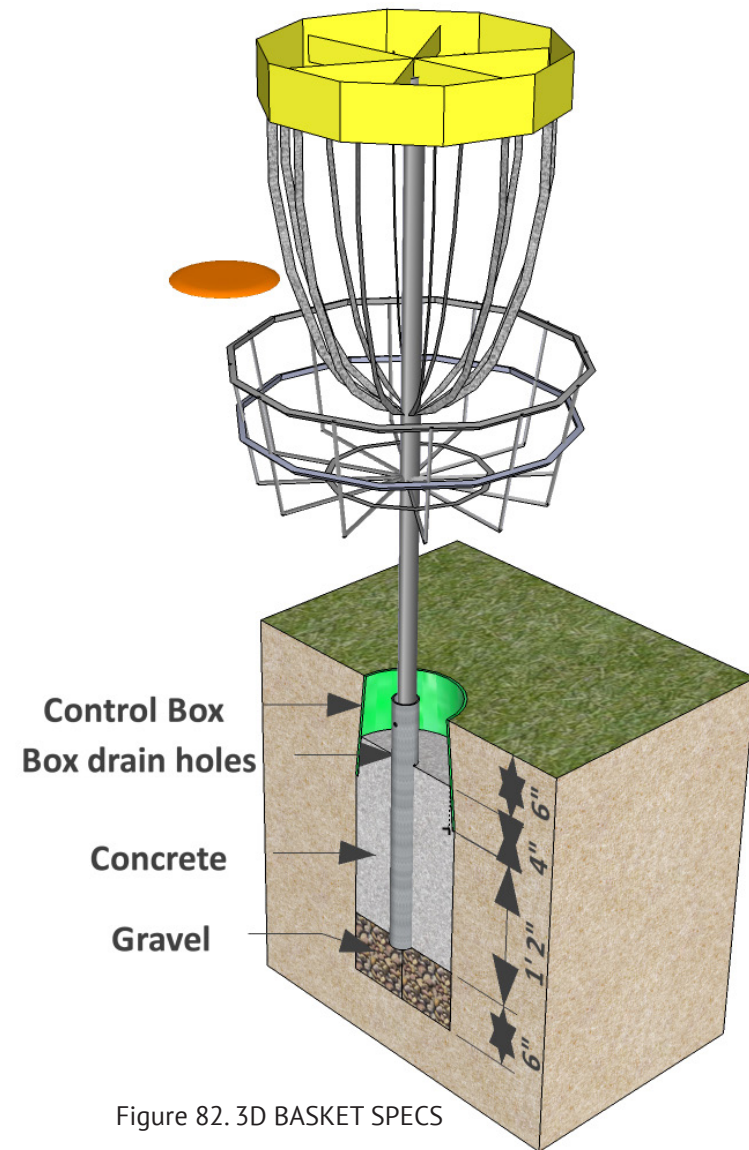

Figure 82. 3D BASKET SPECS

# BASKET SPECIFICATIONS:

Target Placements  
allowed under current  
PDGA Specifications

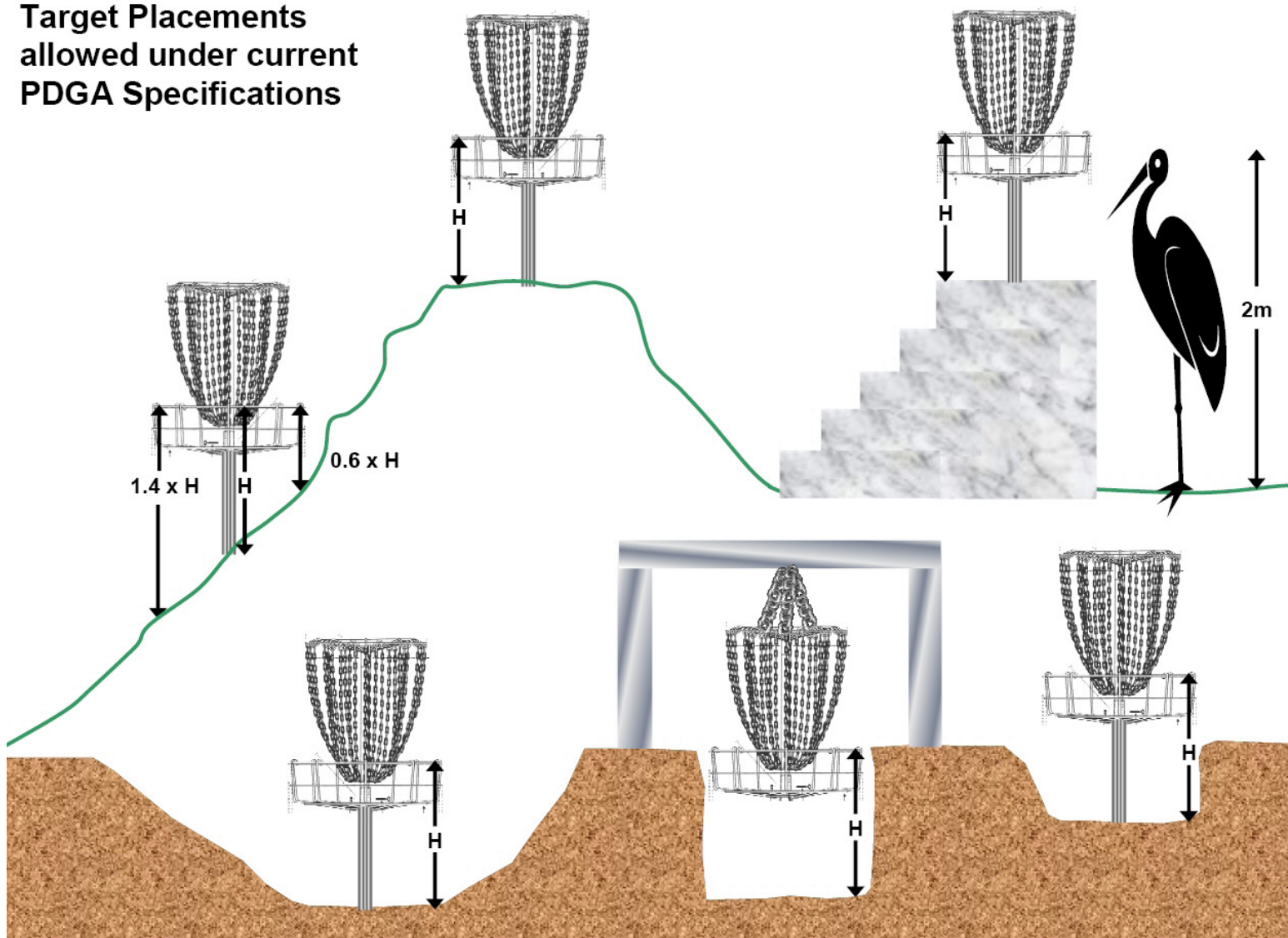

Figure 83. Basket placement standards

# CREATIVE BASKET PLACEMENTS:



Figure 84. River basket placement.



Figure 85. Trunk basket placement



Figure 86. Rock basket placement.



Figure 87. Golden Gate Course: Basket Placement

# STANDARD COURSE SIGNAGE

### Course Signs

Large Course Overview and Custom Rules & Safety  
Make your course safe and accessible for visitors and competitions.

#### Course Overview

24" x 36"

#### Rules & Safety

12" x 18"

Figure 88. Houck Design Signage

Figure 89. Innova Tee Sign

Figure 90. Out of Bounds Sign

Figure 91. Houck Design: Next Tee

Figure 92. Rules Sign



## GOLDEN GATE COURSE: SITE SPECIFIC SIGNAGE



Figure 93-95. The following signs are located at the Golden Gate course. They include: Tee sign, Do not disturb planted area, Look before throwing, Do not litte.

# RECYCLING: LEARNING FROM GOLDEN GATE



Figure 96. Hole 14 Tee Sign



Figure 97. Sitting Stump SF



Figure 98. Tree Cover at DeLaveaga



Figure 99. Left Over Stumps Near the UCD Arboretum.



Figure 100. Safety Net at Golden Gate Course

ESSENTIALS

# X STEP STANCE

BY DAVE DUNIPACE, ILLUSTRATIONS BY TOM BRANT

## 1. Front foot STEP

The x step moves you smoothly from the back of the tee pad to the front and into position to throw. It really is a “step, hop and a step” during which your momentum moves smoothly forward. The solid color represents weight placement. Three green arrows indicate the movement of the body from the back to the front of the tee.

## 2. HOP to left foot

The x step begins (and ends) with both feet perpendicular to the target. Weight is on the front foot. The back foot pushes off to the hop and begins to slide behind the front foot. The body moves forward toward the plant and throw.

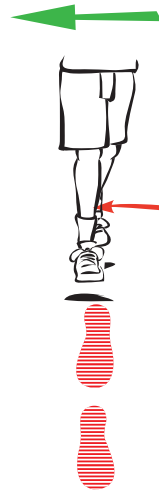

2b. The left foot lands with hips rotated back in position to throw. Your right foot is off the ground in preparation toward the plant step.

## 3. Front foot STEP to plant

When the lead foot plants the throw begins. Your hips rotate first followed by shoulders and arm motion. When your weight transfers and your hips and shoulders rotate, the back heel lift and eventually so does the entire back foot in the follow through. Just after release of the disc the front foot must pivot to relieve stress on the knee.

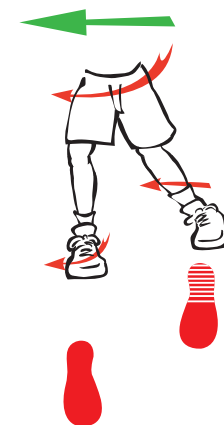
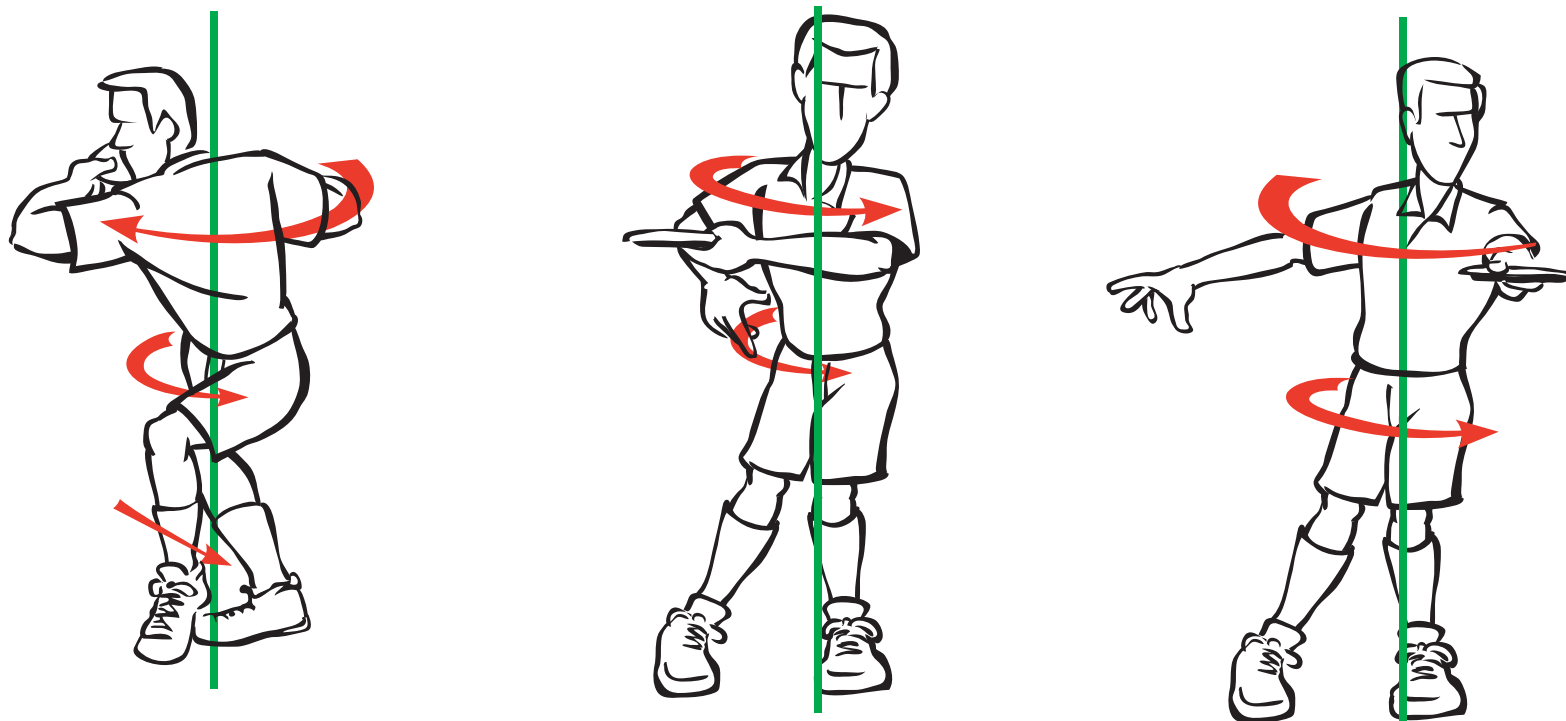

Figure 101. X Step Demonstration

# BACKHAND DRIVE

BY DAVE DUNIPACE, ILLUSTRATIONS BY TOM BRANT

Figure 102. Backhand Drive



**1.** The arms are tucked in close to the torso. The upper body opposite of the throw as the front foot moves forward to the plant position. Center of gravity is behind the front foot. The throwing elbow should start as far back as is possible while still able to rotate quickly forward.

**2.** The shoulders and upper arm continue to turn as the elbow extends the disc into the snap position. The disc begins to pivot at the end of the elbow extension and will rip itself out of the grip as the arm and shoulders pull through with maximum force. The center of gravity moves up on the plant foot.

# BACKHAND DRIVE CONTINUED

BY DAVE DUNIPACE, ILLUSTRATIONS BY TOM BRANT

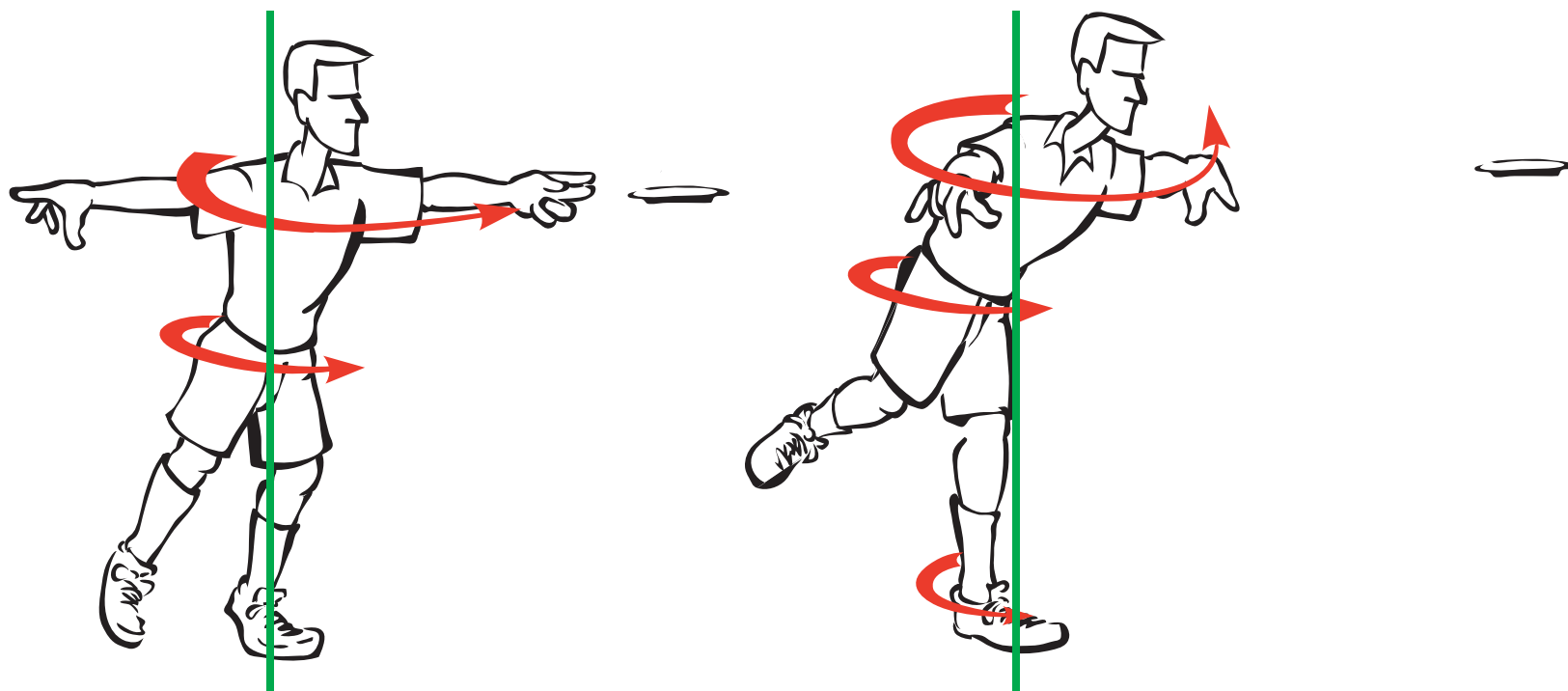

**3.** The disc is released as weight now is over the plant foot. The left foot comes off the ground and the plant foot begins to pivot in the follow-through motion.

**4.** The follow through pivot is necessary to relieve stress on the plant foot's knee, and to ensure maximum pull through power and speed. Momentum should be so great at this point, that it makes a pivot necessary.

# PART 04



Figure 103. Golden Gate Course: Teeing Off

# HOLE ATTRIBUTES KEY

<b>O</b> Open Shot	Refers to a hole where there isn't much vegetation/trees in the flightpath of the disc.
<b>L</b> Long Shot	Refers to a hole that is longer than 400 ft depending on the pin placement.
<b>D</b> Difficult	The difficulty level of each hole is based on the presence of natural obstacles, water hazards, out of bounds, and topography changes.
<b>OB</b> Out of bounds	Out of bounds refers to areas where the disc is not allowed to touch the ground such as pathways or restricted areas. Players who land out of bounds shall receive a stroke.
<b>WH</b> Water Hazard	Refers to water bodies present in the flightpath of a disc. Landing in water is a stroke against a player's score.
<b>B</b> Backhand Shot	Common Throwing style where the throwing side of the body is pointed towards the target. Player reaches across chest then throws the disc across the body.
<b>F</b> Forehand Shot	Throwing style that leads with the non-throwing arm.
<b>M</b> Mandatory	Refers to a hole that is near a pedestrian pathway and therefore, a specific route must be taken in order to avoid hitting them.
<b>W</b> Wooded Area	Refers to a hole that is located in an area that is significantly vegetated.



OB  
F  
D  
L



W  
F  
B



B  
D  
O  
WH  
L



F  
B  
O

Figure 104. Hole Attributes Key

# HOLE INDEX: PHASE 1 & 2

HOLE	1	2	3	4	5	6	7	8	9	10
PIN 1 <small>PAR</small>	275' <sup>3</sup>	300' <sup>3</sup>	270' <sup>3</sup>	470' <sup>3</sup>	320' <sup>3</sup>	215' <sup>3</sup>	220' <sup>3</sup>	310' <sup>3</sup>	220' <sup>3</sup>	225' <sup>3</sup>
PIN 2 <small>PAR</small>	340' <sup>3</sup>	400' <sup>3</sup>	415' <sup>3</sup>	600' <sup>4</sup>	410' <sup>3</sup>	290' <sup>3</sup>	300' <sup>3</sup>	N/A <sup>3</sup>	310' <sup>3</sup>	280' <sup>3</sup>
<b>QUALITIES</b> <small>SEE HOLE KEY</small>	O B F OB	O B F	W L OB F	O L F B	O L F B	W F B	O F B	W OB D B	W F B	W F

HOLE	11	12	13	14	15	16	17
PIN 1 <small>PAR</small>	275' <sup>3</sup>	350' <sup>3</sup>	260' <sup>3</sup>	260' <sup>3</sup>	320' <sup>3</sup>	250' <sup>3</sup>	230' <sup>3</sup>
PIN 2 <small>PAR</small>	310' <sup>3</sup>	460' <sup>3</sup>	310' <sup>3</sup>	315' <sup>3</sup>	440' <sup>3</sup>	340' <sup>3</sup>	310' <sup>3</sup>
<b>QUALITIES</b> <small>SEE HOLE KEY</small>	O B F WH L	O B F L	W F B	O L F B	O L F B	O F B L	W F B M

The following key provides estimates as to how long each hole is for both basket placements. This was done by opening a campus map file in Vectorworks, scaling it, wand drawing lines from the location of the desired tee pad to the two suggested basket placements. The index also provides symbols from the hole key, that help describe each hole's attributes.

Figure 105. Hole Index



# MASTER PLAN OVERVIEW

The proposed master plan for a disc golf facility aimed to highlight the natural beauty of the UC Davis Arboretum, educate players about its value and provide students with an alternative recreational activity. It was my goal to design the course in such a way that it would passively move players across the entire Arboretum with the intention of showcasing the various botanical gardens and their assigned signage. In terms of course design, the focus was to provide a well balanced course that would allow players to use different discs for different types of conditions.

After carefully reviewing my findings from the conducted site analysis, and getting input from the Arboretum staff and committee member Jim Oates, I determined that no matter how much signage I provide or how well

I designed each hole, the safety for users could not be guaranteed. Not to mention the health of trees & shrubs within the range of each hole. Although it sent me back to the drawing board I learned just how much community members care about the well being of the Arboretum. It was because of this finding that I had to re-envision the course and my educational approach to it.

The final product, consists of a seventeen hole course that encompasses the west end of the Arboretum. This time around, I was able to place most holes away from areas of high pedestrian use and away from sensitive areas. Sitting spaces and tee signs were designed from left over stumps that can be found throughout the entire Arboretum. This idea was inspired from my visit to

---

# MASTER PLAN OVERVIEW

The Golden Gate Park course in San Francisco, in which I noticed that most of their structures were made from stumps.

This would decrease the cost of how much it would cost to put the suggested course into place. Along with the course design, I provided an educational plan aimed to be used in a physical education course as a way to teach the basic skills of disc golf and the value of the Arboretum.

# MASTER PLAN: PHASE 1



Figure 106. Master Plan: Phase 1

# MASTER PLAN: PHASE 2



Figure 107. Master Plan: Phase 2

---

---

# HOLE ENLARGEMENTS

The following illustrations aim to highlight the top three hole placements from each phase. Natural elements such as tree canopy, elevation changes, wind exposure and water hazards were the deciding factors for each choice. The goal was to prevent repetition of graphics of holes that share the same qualities. In terms of the graphics for each hole, only those holes that showed significant topographic changes have section drawings. Depending on the course, topography can play an important role on the difficulty and enjoyment of the game. Therefore, I felt depicting elevation changes would help visualize the hole better. The rest of the holes aim to show visuals of what it's like to tee off and to putt to the basket through photo-realistic perspectives. Lastly, all holes have an enlargement showing existing tree canopy, roads, water, topography lines, and any structures that might have been added.

# HOLE 1: A CLOSER LOOK

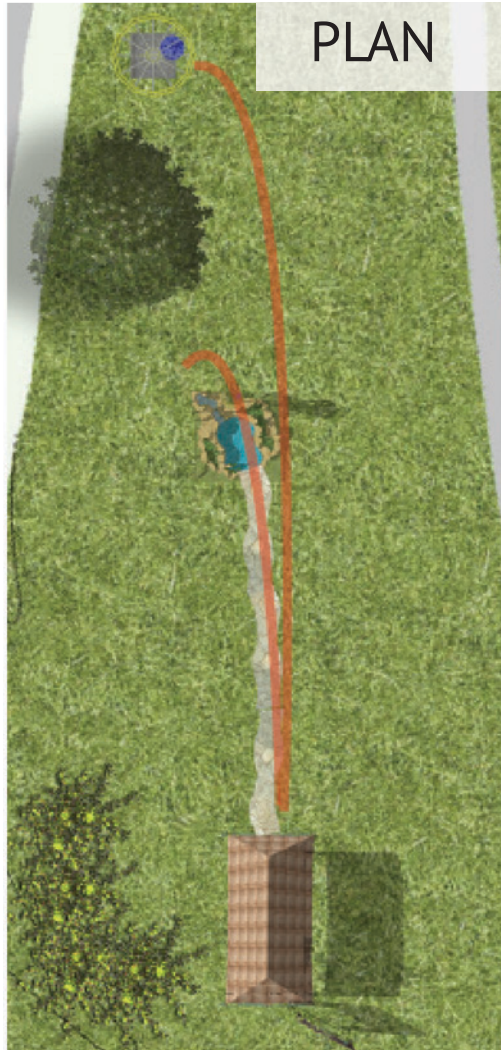

Figure 108-110. Hole 1: Plan View, Basket 1 & Tee Pad Perspective.

# HOLE 3: A CLOSER LOOK

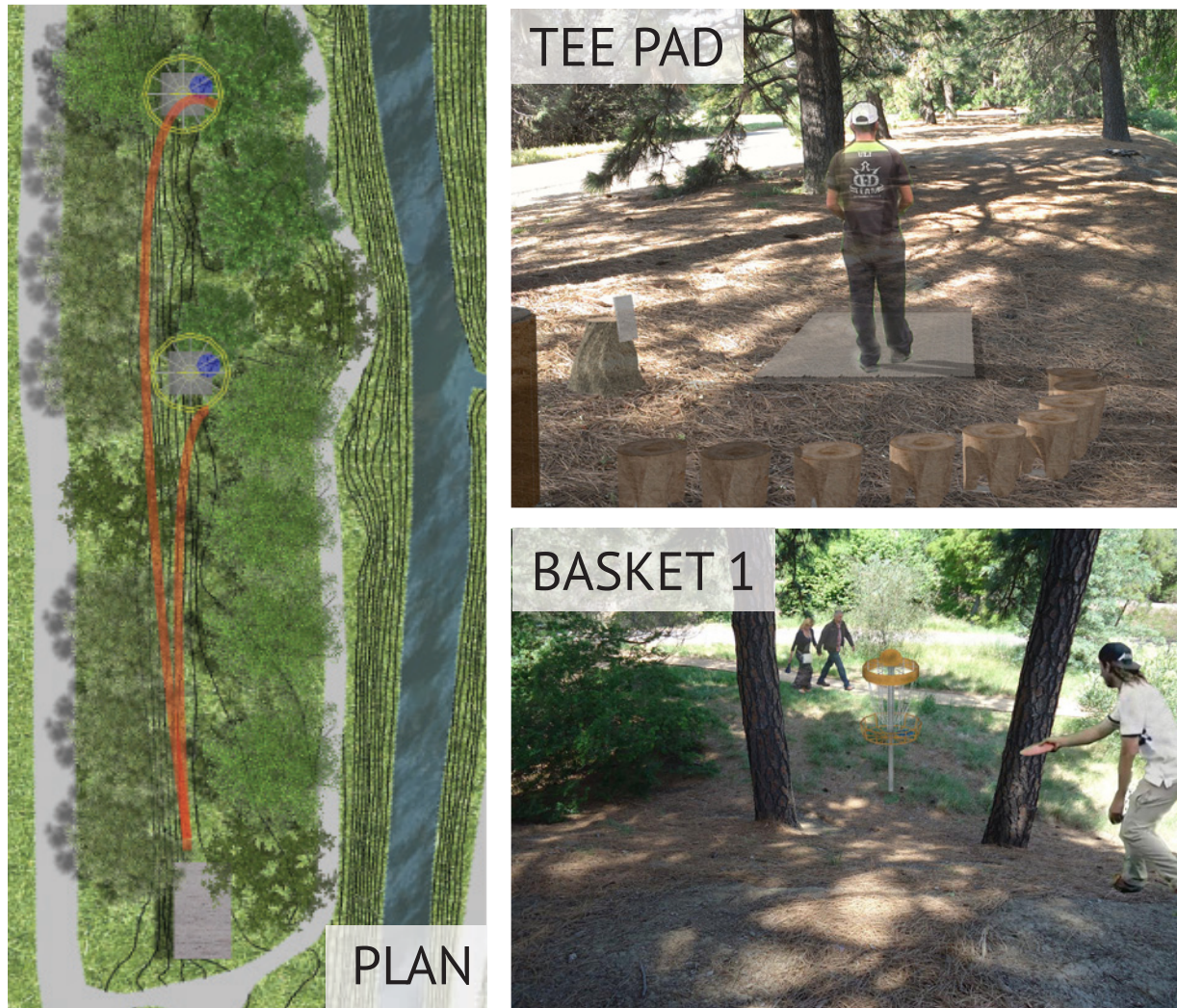

Figure X Graphics and text was borrowed from Innova's website pdf files.

Figure 111-113. Hole 3: Plan View, Basket 1 & Tee Pad Perspective.

# HOLE 7: A CLOSER LOOK



Figure114-116. Hole 7: Plan View, Basket 1 & Section View.



# HOLE'S 8 & 9: A CLOSER LOOK

Figure 117-118. Hole 8-9: Tee Pad Perspectives.



# HOLE 11: ENLARGEMENT

DESIGN

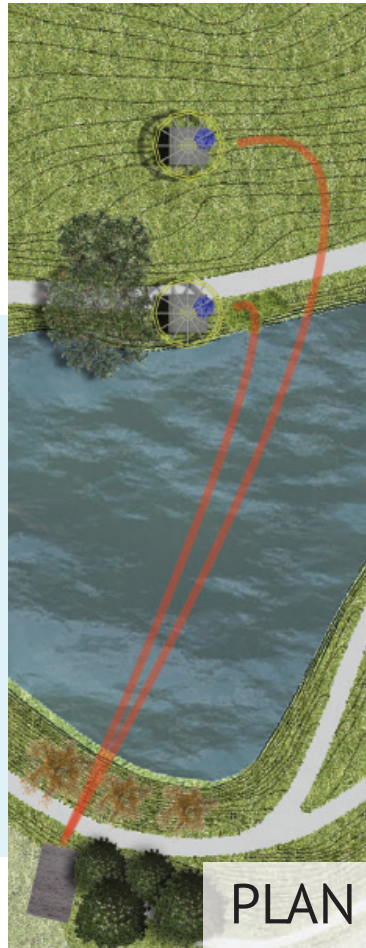
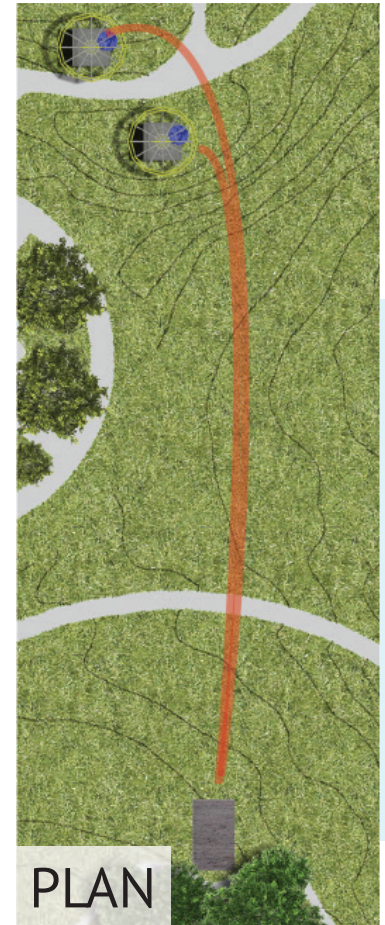

Figure 119-121. Hole 11: Plan View, Basket 1 & Section View.



# HOLE 15: A CLOSER LOOK

Figure 122-124. Hole 15: Plan View, Basket 1 & Section View.



# HOLE 17: ENLARGEMENT

DESIGN

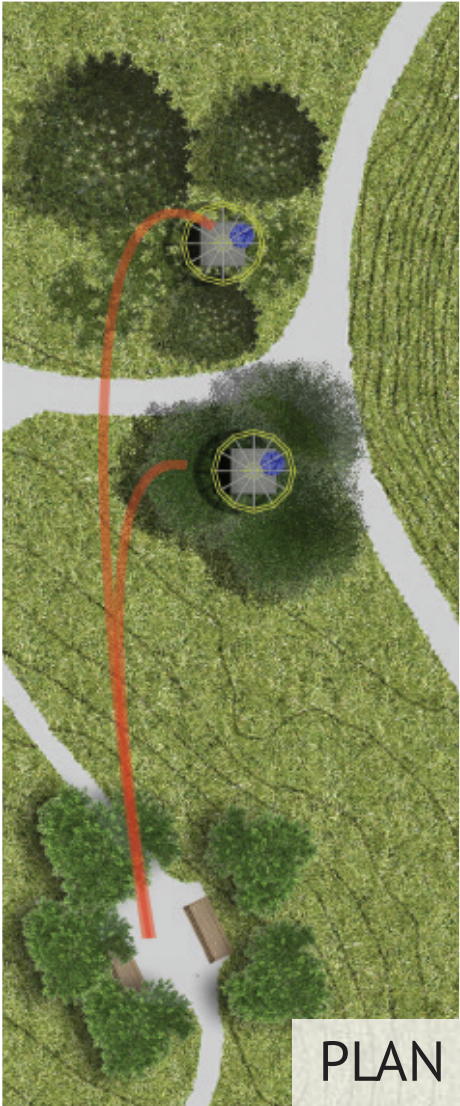

Figure 125-127z. Hole 17: Plan View, Basket 1 & Tee Pad Perspectives.

---

# FINAL THOUGHTS

During the early stages of the project, the intention was to put into place a disc golf course that would actually have the chance to be built. From the beginning, it was understood that safety of users and health of plant life would dictate whether or not a disc golf course was suitable for the Arboretum. My early approach, intended to eliminate these concerns by providing proper signage and by placing holes away from pedestrian lines of traffic. After reaching out to members of the Arboretum and course designers I came to the realization that building the course would encounter more resistance than anticipated due to the fact that damage to plant life could not be prevented. For this reason, it was extremely difficult to blend the already established identity of the Arboretum with the sport of disc golf.

Near the end of the project, I had to modify my approach, the extent of my site, and my educational approach to the whole project. In the end, I decided to respect all concerns by eliminating the first twelve holes I had originally suggested. As a result, I was driven to look at a part of the Arboretum that I had previously neglected due to the lack of topography and tree canopy. Although not the original vision, the final product was still able to capture the intended goals I originally had in mind.

# WORKS CITED

Johnson, Ryan. Personal Interview. 17th April 2013

Lyksett, Jon. "What is EDGE?" Educational Disc Golf Experience. 7th June 7 2013.

<<http://www.edgediscgolf.org/introduction.htm>>

Oates, James. Personal Interview. 7th May 2013

Palmeri, Jim. 2008. "Brief History of Disc Golf." History . Professional Disc Golf

Association. September 9th, 2008. Web. 19 Mar 2013.

<<http://www.pdga.com/history>>.

Rothstein, R. 1996. "Disc golf world news." First Tee, 39:3.

Simmons. "Course Brochure ." Innova Disc Golf. Innova Champion Discs Inc., n.d.

Web. 19 Mar 2013. <[http://www.innovadiscs.com/downloads/course-](http://www.innovadiscs.com/downloads/course-brochure.html)

[brochure.html](http://www.innovadiscs.com/downloads/course-brochure.html)>.

Siniscalchi, Jason. 2004. The Personal and Community Benefits of Disc Golf to Rural

America (and Beyond). MA thesis. West Virginia University, 2004. Print.

<<http://www.pdga.com/files/documents/BenefitsOfDiscGolf-Siniscalchi.pdf>>.