

# the modern farmer

a graphic guide to urban agriculture

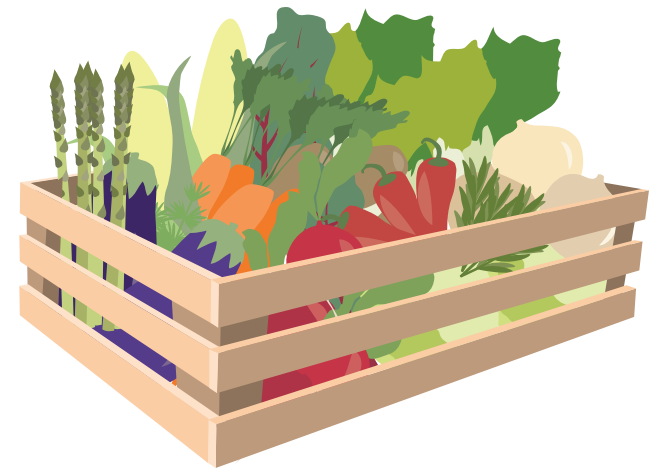

JOSEPH CAFUIR



# the modern farmer

a graphic guide to urban agriculture

A Senior Project presented to the faculty of the  
Landscape Architecture Department of the University of California, Davis,  
in partial fulfillment of the requirements for the  
Degree of Bachelors of Science in Landscape Architecture

Accepted and approved by:

---

**Claire Napawan**  
*Faculty Senior Project Advisor*

---

**Raoul Adamchak**  
*Committee Member*

---

**Monica Perrone**  
*Committee Member*

**By Joseph Cafuir**  
June 10th, 2011



# ABSTRACT

Urban agriculture is not a new practice, but it is still an unfamiliar concept for much of the general public. This is unfortunate, as it has the potential to solve many societal issues. Our industrialized food system is flawed and is negatively affecting our environment, our economy, and our health. In addition, there are many wasted spaces in cities: balconies, rooftops, vacant lots, front yards, and backyards, and people need to know that there is a lot of opportunity in this “dead space.” As a student of landscape architecture, I would like to spread the word about how you can create gardens that are both beautiful and productive.

Rather than creating a single-serving design for a site implementing urban agriculture, I have chosen to create a tool that others can use to implement the ideas themselves. I created a guidebook in order to convey the ideas and techniques of urban agriculture and design through simple graphics. We are all visual learners, so I hope that this guidebook stimulates you and pushes you to strive for a more intimate connection between yourself, your food, and the environment.



# DEDICATION

To my parents, Rico and Jocelyn.  
Thanks for all the love and support.





# ACKNOWLEDGEMENTS

This project would not have been possible without the support I have received from my committee members, family, friends, and fellow classmates.

**Raoul, Monica, & Claire** - Thanks for all the great advice and positive energy that you've provided me with throughout this entire process.

**My family** - Thanks for the unconditional love and support throughout all these years. I couldn't have done any of this without you.

**My friends** - Thanks for making the past four years of college the best four years of my life so far, and thanks for understanding during those times when I couldn't hang out because I had to "go to studio and color all night."

**My classmates** - Thanks for all the inspiration, support, and entertainment during the past few years. I'll never forget about all the great times we've shared, and I'm truly going to miss the long days and nights spent with you guys in Hunt Hall. The friendships that we've formed will never be forgotten. It's been an honor working with such a talented and creative group of people, and I look forward to seeing all of you do great things in the future.



# CONTENTS

## 01

### the process

- 03 Our Industrialized Food System
- 04 Urban Agriculture as a Solution
- 06 Case Studies
- 09 Bringing It All Together

## 11

### the product

- 13 Front Cover
- 19 Contents
- 21 Choosing Your Site
- 24 Soil
- 28 Plants
- 32 Planting In Small Spaces
- 37 Maintenance
- 46 Harvesting
- 48 Prototype Designs
- 56 Back Cover

## 57

### conclusion

- 59 Bibliography
- 61 Figure Sources
- 62 Appendix



# LIST OF FIGURES

- 1.1 - A peak into large scale industrial agriculture
- 1.2 - Mrs. Obama working with local schoolchildren in the White House Kitchen Garden
- 1.3 - Urban Agriculture in Havana, Cuba
- 1.4 - Residents of Havana, Cuba, selling produce harvested from urban gardens
- 1.5 - Clarence and Rudine Ridgley's front yard contrasted against neighboring traditional lawns in Baltimore, Maryland
- 1.6 - The Ridgley family's highly productive front yard garden
- 2.1 - Front cover
- 2.2 - Title page
- 2.3 - Introduction
- 2.4 - Contents
- 2.5 - Plants in containers
- 2.6 - Front yard edible landscape
- 2.7 - Figure watering plant
- 2.8 - Hand holding soil & soil pH scale
- 2.9 - Soil texture flow chart
- 2.10 - Soil nutrient exchange
- 2.11 - Diagram: crop rotation
- 2.12 - Newly sprouted seedling
- 2.13 - Step by step: how to start seeds
- 2.14 - Step by step: how to break up root bound plants
- 2.15 - Step by step: how to transplant seedlings
- 2.16 - Diagram: groupings vs. rows
- 2.17 - Diagram: companion planting
- 2.18 - Step by step: how to build a raised bed
- 2.19 - Step by step: how to build a raised bed (continued)
- 2.20 - Step by step: how to turn household items into containers
- 2.21 - Plant being watered
- 2.22 - Grouping of plants
- 2.23 - Diagram: weed prevention
- 2.24 - Browns and greens for composting
- 2.25 - Diagram: composting
- 2.26 - Step by step: how to compost with worms
- 2.27 - Step by step: how to compost with worms (continued)
- 2.28 - Chart: pest and disease management
- 2.29 - Chart: pest and disease management (continued)
- 2.30 - Harvesting basket
- 2.31 - Harvesting chart
- 2.32 - Hanging tomato plant
- 2.33 - Balcony prototype design
- 2.34 - Front yard prototype design
- 2.35 - Community garden prototype design
- 2.36 - Sources
- 2.37 - Back cover
- 2.38 - Front yard prototype design (full graphic)
- 2.39 - Community garden prototype design (full graphic)



# the process

I plan to study urban agriculture and how it can be implemented into daily life in urban areas. My goal is to create a guidebook that will serve as an introductory lifestyle and design guide to urban agriculture for the average person. My objective is for my project to answer the following questions:

- 1. What is urban agriculture and what makes it so important to society?*
- 2. What techniques can anybody learn to implement urban agriculture into their daily lives?*
- 3. How can anybody combine good design with urban agriculture to create the ideal site?*

My original inspiration for this project came from classic “first-time farmer” guidebooks and the Farmers Almanac. My idea is to modernize these classic books and intertwine design with urban agriculture to create a reader-friendly, graphic guidebook for the “modern farmer.” My first step was to research urban agriculture and learn its significance in today’s society.





## Our Industrialized Food System

How much longer can we depend on our flawed food system? Our current industrialized food system is defective in many ways. It has been contaminated for far too long with genetically modified organisms, or GMOs. Genetically modified seeds are manipulated in laboratories so that when they are planted and grown, desired traits in the plants are increased, such as a higher resistance to herbicides and improved nutritional content. However, there are many problems with genetically modified food. They have been shown to have harmful effects on humans, animals and plants. People have been eating food produced this way since the 1990s, and unfortunately, many do not even know that they exist.

In order to force plants to grow in bad conditions, conventional farmers use fertilizers made from fossil fuels, which are a nonrenewable energy resource. When this fertilizer is mixed with dirt and used to make plants grow, the soil is stripped of all its nutrients, leading to land degradation. Intensive farming has led to a cycle of exhaustion of soil fertility, lowering agricultural yields. Currently, forty percent of the world's agricultural land is seriously degraded and for the most part, extremely unproductive (Sample). When agricultural land is lost, we move towards deforestation, which negatively affects our natural ecology.

Within the industrialized food system, fruits and vegetables are sprayed with harmful chemicals, such as pesticides and herbicides, to kill weeds and bugs. When it rains, these chemicals seep into the ground and end up in our waterways, poisoning our waterways also.

Finally, the food is tampered with even more after being harvested so that it can travel thousands of miles from farm to supermarket without degrading in quality. Food grown on conventional farms is irradiated (exposed to ionizing radiation, to destroy microorganisms, bacteria,



*Fig. 1.1 - A peek into large scale industrial agriculture*

viruses, or insects that might be present in the food) to keep food “fresh” longer. It can also be heavily processed and loaded with sugar, salt, fat, preservatives and other additives in order to retain flavor.

We do not have much time left to live off of this industrialized food system. The conventional food system relies on fossil fuels for almost every phase of food production, from the manufacturing of fertilizers, pesticides and herbicides to the transportation of the final food products thousands of miles from farms to supermarkets (Nordahl 18). Unfortunately, the era of cheap and abundant fossil fuel as an energy source is soon coming to a close. We are quickly running out of productive farmland and our cities are growing at an unsustainable rate.

However, there is still a way to fix our unfortunate situation. Smaller, localized agricultural efforts are needed in and around our cities. There is no reason for us to rely on industrialized agriculture for the rest of our lives. We have an abundance of underutilized land in cities that can be repurposed for providing communities with much needed organic and locally grown food. This brings us to the idea of urban agriculture, which is simply the practice of agriculture within a city (Viljoen, Bohn and Howe 21). The concept is nothing new, but is relevant today more than ever, and sorely needs to be reintroduced to our society.

## Urban Agriculture as a Solution

During WWII, twenty million small gardens spread throughout cities were able to supply 40 percent of the fresh vegetables consumed in America (Rain). These gardens were planted in order to help fight the food shortage that the war had caused, as well as act as a morale booster for gardeners who wanted to feel like they were contributing to the war effort. Americans became very concerned about food production and the federal government created programs to help educate citizens and help them take advantage of food growing opportunities throughout urban areas.

These community agricultural efforts were able to stabilize our nation’s food supply when the rural farms were unable to keep up with the demand. These activities allowed those who were not fighting at the front line to participate in the war efforts, helping spread patriotism while simultaneously providing a form of recreation to help distract from the troublesome war.

In March 2009, First Lady Michelle Obama brought back the idea of the victory garden by planting a “Kitchen Garden” on the White House lawn. This was the first vegetable garden at the White House since Eleanor Roosevelt’s victory garden during WWII. The purpose of the garden was to provide food for the presidential family’s meals and formal dinners, but also, Mrs. Obama said, “to help educate children about healthy, locally grown fruit and vegetables at a time when obesity and diabetes have become a national concern” (Burros).



*Fig. 1.2 - Mrs. Obama working with local schoolchildren in the White House Kitchen Garden*

Now more than ever, the need for urban agriculture efforts could not be greater. Mrs. Obama, along with other “urban farmers” have started what we hope is a new revolution in urban agriculture. Our current food system is leading to detrimental environmental and societal health issues, so attention to urban agriculture needs to keep increasing. Urban agriculture can provide our society with environmental, social and economical benefits. It has the potential to enhance food security, nutrition and health, help create job opportunities and help create and maintain much needed green open spaces in urban areas.

Thankfully, our society has taken notice and has began questioning our tragic food system. Many are now aware of the quality and cost, both financially and environmentally, of food from our industrialized food system. Because of this, many have transitioned into buying locally grown, organic food that does not have to travel thousands of miles from farm to plate.

Organic produce is free of chemicals such as pesticides and herbicides, which are frequently found in residues on produce from

conventional agriculture. Keeping chemicals out of our body is better for our health. Organic food is also often fresher, because it does not contain preservatives that are usually applied to make it last longer, and it is a commonly known fact that fresh food tastes better.

Organic food production is also better for the environment in a multitude of ways. Organic farming practices create less air, water and soil pollution than conventional agriculture practices, and it also conserves water, increases soil fertility and requires less energy. Since organic farming is chemical free, it is better for wildlife and for the people who work on the farms.

While some have shifted towards organic, local food, most people in our society have not. After surveying 100 people, I learned that a little over 80 percent of them buy the majority of their produce at a chain supermarket, while 10 percent purchase from local markets, 5 percent from local cooperative markets and just 4 percent from local farmer's markets. Only 1 percent stated that they grow a majority of their produce themselves. Of those surveyed, only 15 percent claimed that the majority of the produce they purchase is certified organic or locally grown. 70 percent stated that the main reason they do not purchase organic or locally grown food is because of its high price. Urban agriculture needs to become more prominent in order to help raise these numbers.

## Case Studies

It has been proven throughout the world that urban agriculture has the potential to help our society become less dependent on the industrialized food system. In turn, a localized food system can tremendously help our society advance socially, environmentally, and economically.

Since the early 1990s, residents of Havana, Cuba have been able to achieve food security by creating a system of urban organic gardens throughout the city. The urban agriculture sector in Havana has been able to create many job opportunities, a fresh food supply to the community and has also helped beautify urban areas.



*Fig. 1.3 - Urban agriculture in Havana, Cuba*

Residents have been very resilient in keeping their localized food system and the work sector that goes along with it alive. They are very committed to the system because of the large amount of employment it brings to the community. By 2003, more than 200,000 Cubans were working in new jobs provided by the expanding urban agriculture sector (Kisner).

Besides providing many residents with jobs, the implementation of urban agriculture has also been able to create a localized food system in Havana. The urban gardens in Havana are able to provide a fresh food supply to the community. Today, 26,000 gardens cover over 6,000 acres of land in Havana, and they are able to produce up to 25,000 tons of food annually (Kisner).

The experience of walking around the city has also been vastly improved since the urban gardens were introduced. They have transformed what were once unattractive, underutilized areas in Havana into lush gardens that help beautify the city. Overall, the implementation of urban agriculture and the addition of green space has made Havana a much more pleasant place to live. The landscape, lifestyle and food supply of Havana residents has been dramatically modified by the implementation of urban agriculture during the last twenty years, and it stands as a great example of what other cities in the world can become.

The book, *Edible Estates*, by Fritz Haeg chronicles examples of urban agriculture on a more personal scale. It tells the story of several sites, mostly front yards, throughout the United States and England that have implemented urban agriculture and currently act as regional prototypes for small scale productive gardens. The Edible Estates project proposes the replacement of the domestic front lawn with a highly productive edible landscape (Haeg 22). The sites chosen to be transformed into prototype gardens were those that had the potential to make the biggest impact and influence on their surroundings. All the designs follow general guidelines that qualify them as Edible Estate



Fig. 1.4 - Residents of Havana, Cuba, selling produce harvested from urban gardens

gardens, but their locations and the people who plant them show that they are unique regionally and culturally. Edible Estates is an ongoing initiative where adventurous residents have offered their front lawns as working prototypes for their regions. The gardens are unique and designed in response to the site itself, the needs and desires of the owner, and the local climate and geography. The prototype gardens and their stories are meant to inspire others. They show that is possible for anyone to grow food in the wasted space in front of their homes. The book presents the stories of real-life gardens and the people who tend to them, mostly in the words of the gardeners themselves.

Regional Prototype Garden #6 can be found in the front yard of Clarence and Rudine Ridgley's home in Baltimore, Maryland. Edible Estates follows their story from the first planting to their second year of gardening in the front yard. Presented through journal entries, homeowner Clarence Ridgley chronicled his family's experience of having a productive garden in their front yard. He learned what grew well and what did not grow well in his garden, what his family enjoyed eating and what they did not like eating, and used that to plan for the next year. He talked about new relationships built with neighbors and how their front yard has helped bring their community together. Overall, the productive garden in their front yard ended up being a huge success.



Fig. 1.5 - Clarence and Rudine Ridgley's front yard contrasted against neighboring traditional lawns in Baltimore, Maryland.



Fig. 1.6 - The Ridgley family's highly productive front yard garden.

## Bringing it All Together

Learning about our struggling food system and urban agriculture as a solution pushed me to create the final product of this project. By researching urban agriculture through literature reviews and examining case studies of successful implementations of urban agriculture on several scales, I was able to get a grasp of how relevant and helpful to society it can actually be. Learning about urban agriculture on a more personal scale helped me connect to it on a different level. I realized that those who currently practice urban agriculture are truly dedicated and really have a passion for it. After learning this, I felt as if it were my job to find a way to spread the message to those who knew nothing about the ideas and techniques associated with urban agriculture.

I conducted preliminary surveys through a social networking site in order to see what people knew, did not know, and wanted to know about their food and urban agriculture. In addition to the information presented throughout my introduction, I learned that the two most common reasons people had for not growing their own food were that they did not have enough land and that they did not have enough time. Many also shared the view that edible gardens were unattractive and too difficult to maintain. My goal in writing this guidebook was to simplify the idea of urban agriculture and make it a much more approachable subject. I want people to know that with a little dedication, they can easily grow food anywhere, in any space, and it can still be beautiful.

I combined my knowledge of landscape architecture, research on urban agriculture, hands-on experience working on a farm, and my newfound interest in graphic design to create this guidebook. I gathered all of my research information and decided what was most important to include in the guide. The chosen information was then translated into simple graphics and reader-friendly text that someone who knows nothing about urban agriculture will be able to understand. These graphics consist of charts, illustrated step-by-step instructions, and diagrams that present the reader with simple techniques that they can use to become urban farmers. The guide concludes with prototype garden designs on several different scales that show how one can bring everything together and design their own site. The main goal of the guide is to convey the ideas of urban agriculture through simple graphics. We are all visual learners, so I hope that this guide stimulates the reader and pushes them to strive for a more intimate connection between themselves, their food, and the environment.





# the product

*The following pages consist of spreads pulled from “The Modern Farmer: a Graphic Guide to Urban Agriculture,” a separate document that I wrote, illustrated, and had professionally printed as the final product of my senior project.*



# the modern farmer

a graphic guide to urban agriculture



Joseph Cafuir

Fig. 2.1 - Front cover

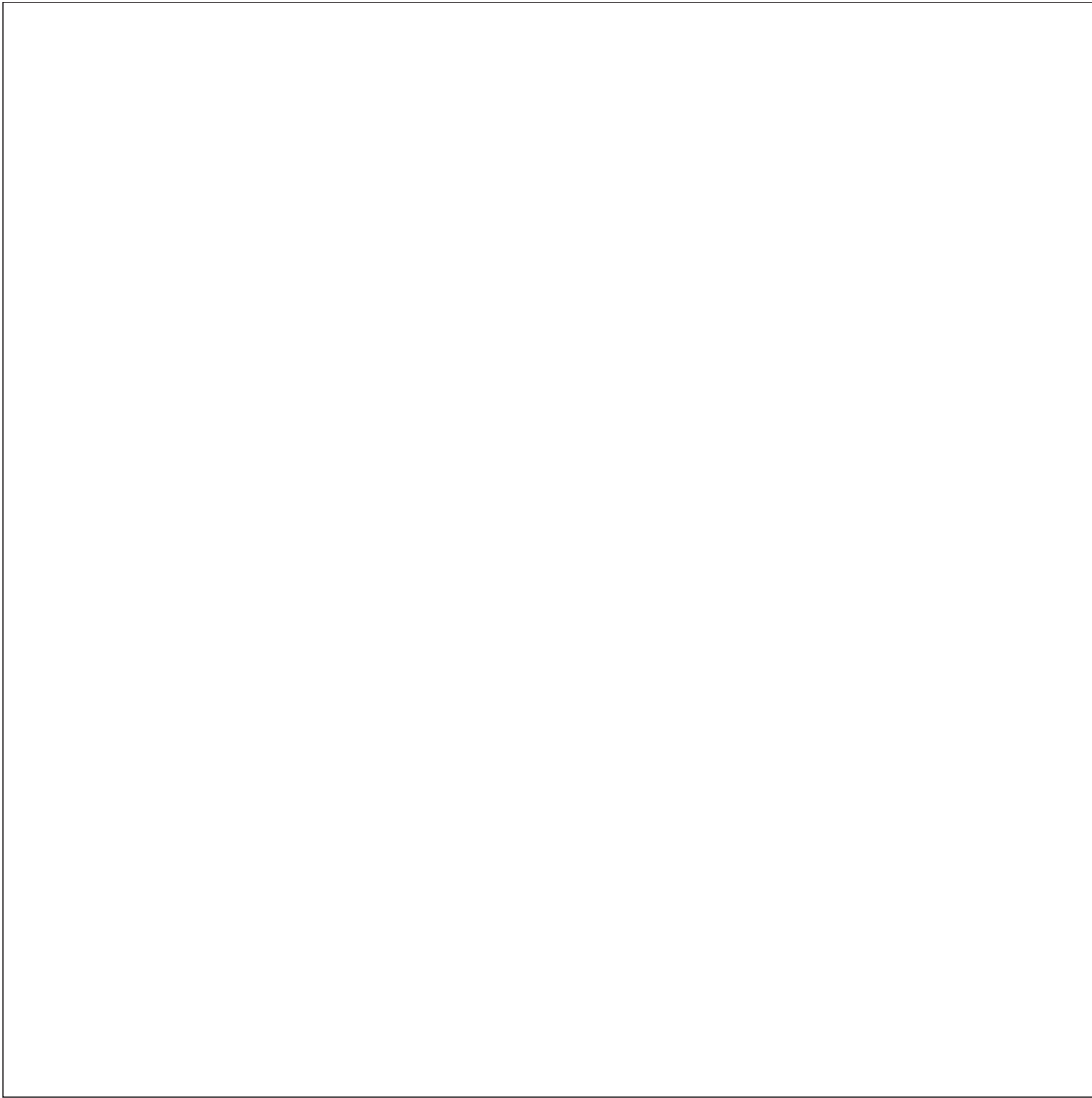

# the modern farmer

a graphic guide to urban agriculture

Written and Illustrated by Joseph Cafuir

*Fig. 2.2 - Title page*

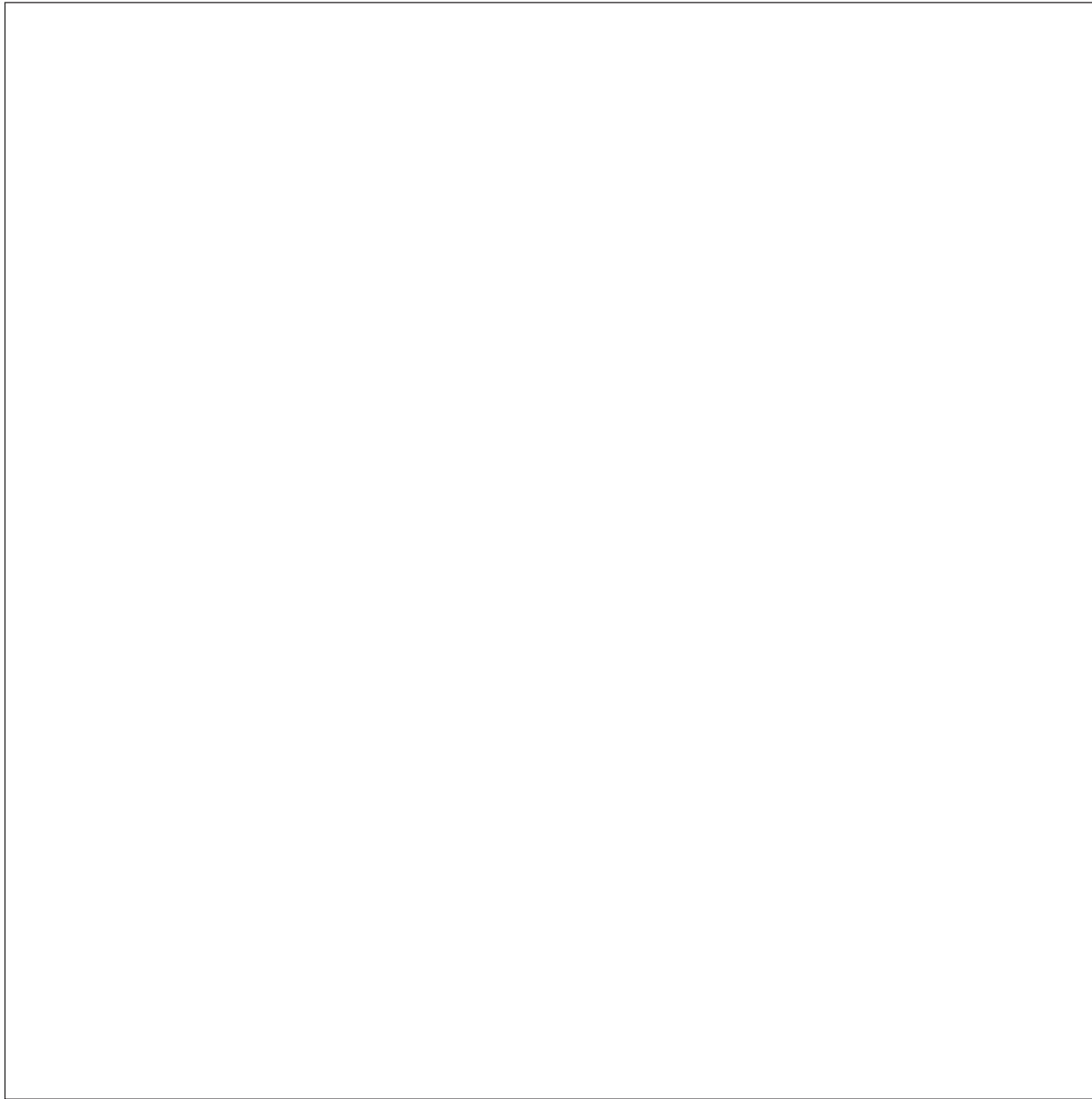

Urban agriculture is not a new practice, but it is still an unfamiliar concept for much of the general public. This is unfortunate, as it has the potential to solve many societal issues. Our industrialized food system is flawed and is negatively affecting our environment, our economy, and our health. In addition, there are many wasted spaces in cities: balconies, rooftops, vacant lots, front yards, and backyards. People need to know that there is a lot of opportunity in this "dead space."

I created this guidebook in order to convey the ideas and techniques of urban agriculture and design through simple graphics. We are all visual learners, so I hope that this stimulates you and pushes you to strive for a more intimate connection between yourself, your food, and the environment.

*Joseph Cafuir  
Landscape Architecture Class of 2011  
University of California, Davis*

*Fig. 2.3 - Introduction*

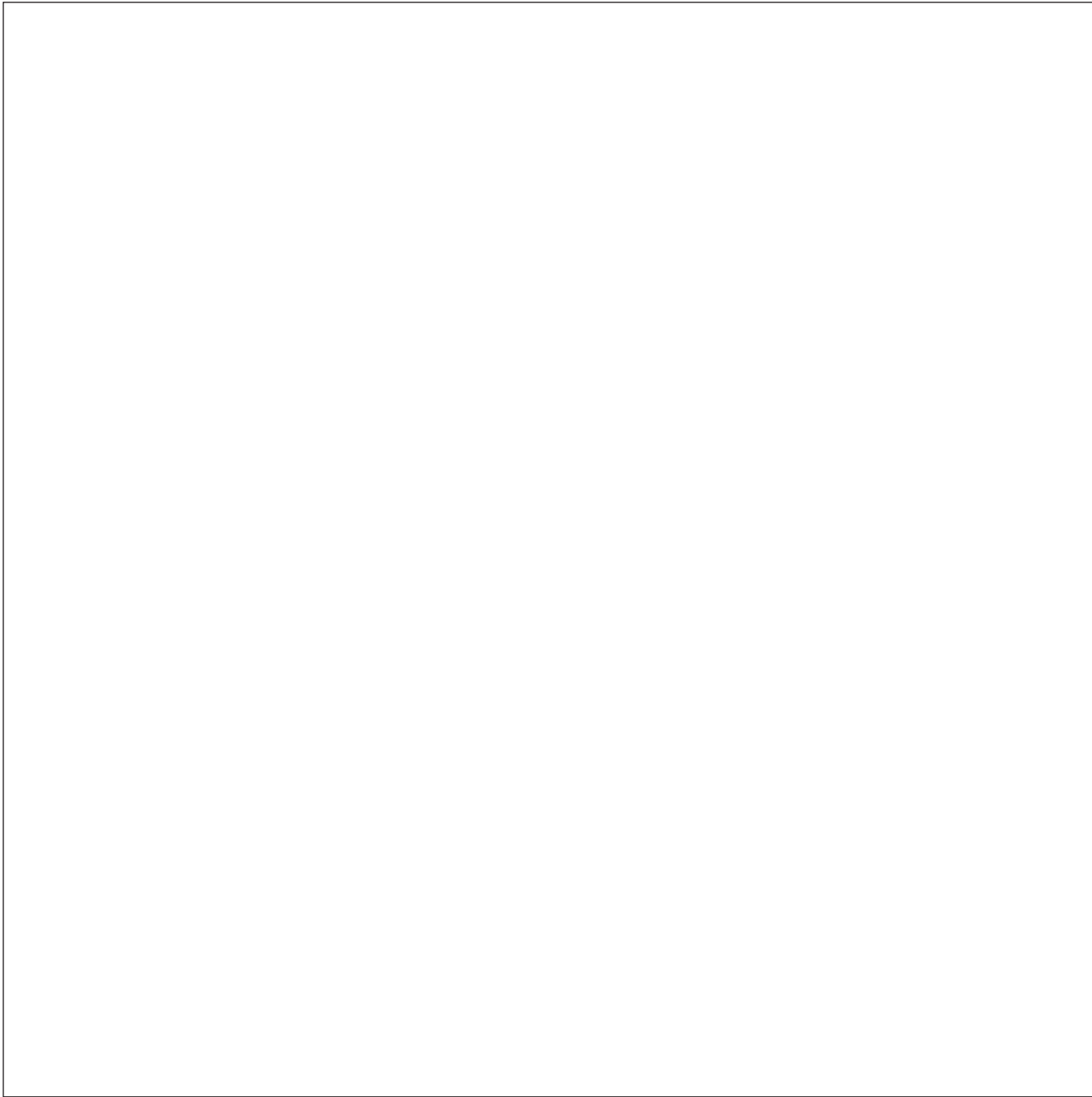



# contents

## **7. choosing your site**

### **10. soil**

11. how to determine your soil texture

13. how to practice crop rotation

### **14. plants**

15. how to start seeds

16. how to break up root bound plants

17. how to transplant seedlings

### **18. planting in small spaces**

19. how to practice companion planting

20. how to build a raised bed

22. how to turn household items into containers

### **23. maintenance**

25. how to prevent weeds from growing

27. how to compost with a garbage bin

28. how to compost with worms

30. how to deal with pests and diseases

### **32. harvesting**

33. harvesting chart

### **34. prototype designs**

35. balcony design

36. front yard design

38. community garden design

### **40. sources**

Fig. 2.4 - Contents

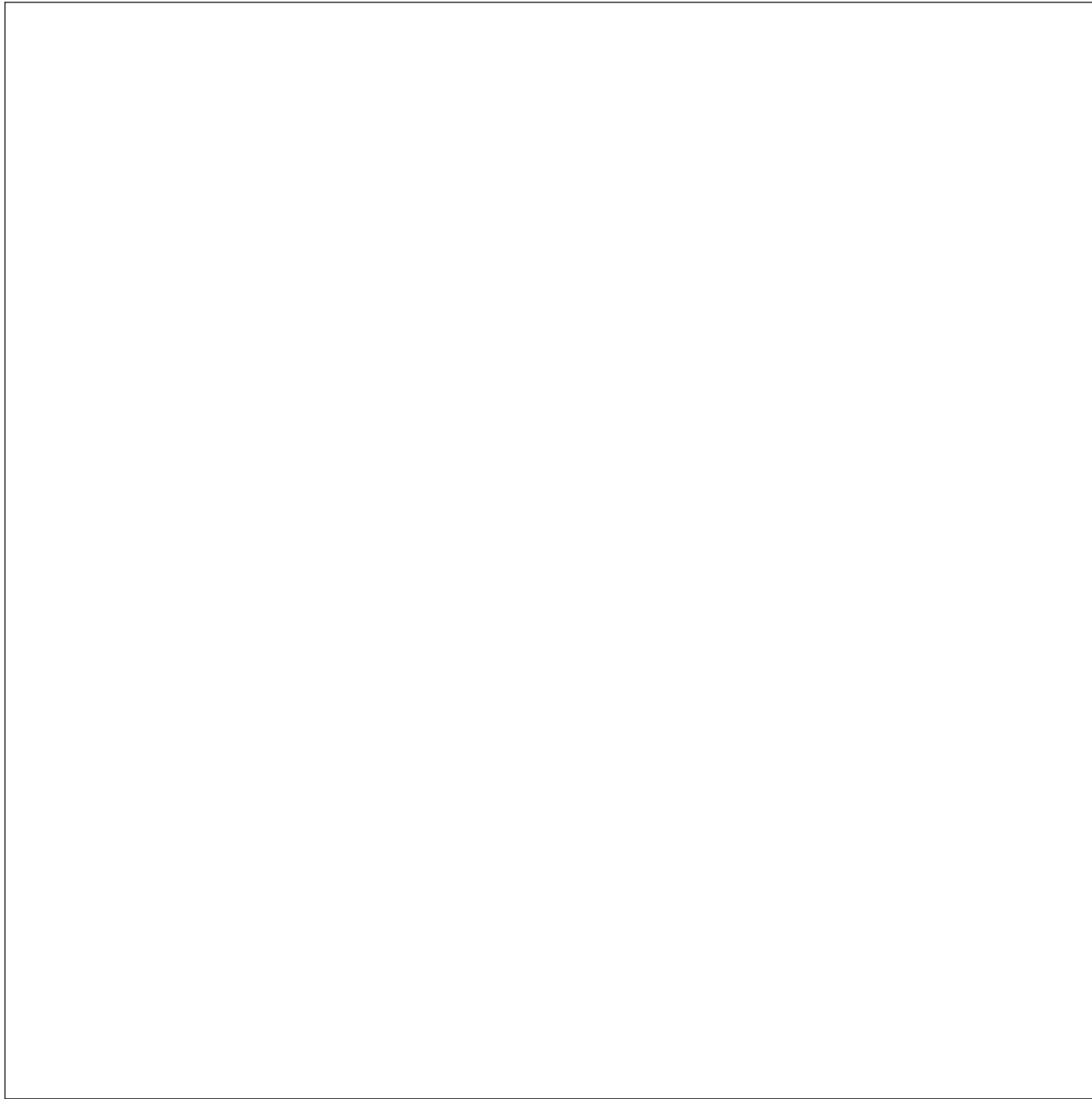

# choosing your site

Every urban garden starts with a site, and whether that site is your cozy balcony or the large vacant lot down the street is up to you.



## Container Gardens

Even if you don't have access to land, you can grow food in containers on patios, balconies, or even indoors, as long as whatever you want to grow has enough exposure to light. Even the most space-deprived can become urban farmers by growing herbs on a windowsill.

## Patio & Balcony Gardens

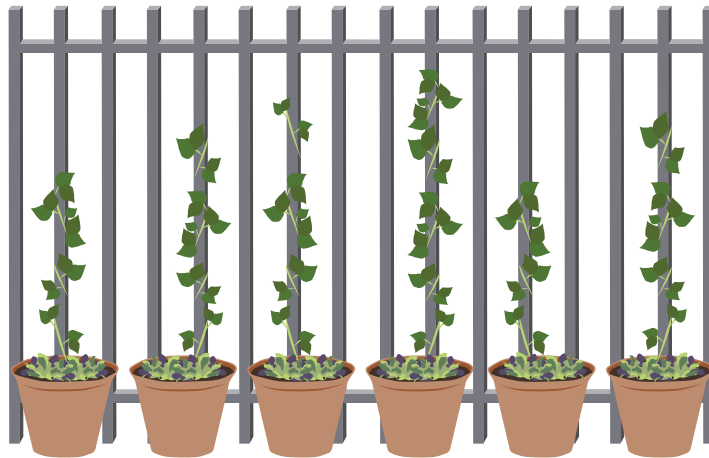

Patios and balconies may seem like confined spaces, but they actually have the potential to provide bountiful harvests. This can be done by maximizing space in all directions. Place a low growing plant and a climbing plant in the same pot, and set it next to your balcony railing. The climbing plant will use the railing as a trellis, and the other plant will grow happily beneath it. If you place a hanging plant above it, then you are growing three things in the space of one.

7

Fig. 2.5 - Plants in containers

## Edible Landscaping

If you are lucky enough to live in a house or on the ground floor of an apartment building, you are likely to have access to a piece of land that you can grow food on. Homes throughout the United States have begun ripping out their lawns and replacing them with edible landscapes, as chronicled in the book, *Edible Estates*.

You can be discreet and plant edible plants throughout your traditional ornamental landscape. For example, you can tuck strawberry plants among flowers in a flowerbed and plant fruit trees instead of shade trees. By implementing these small interventions, your nosy neighbors will probably not even notice that you are secretly farming on your front yard.

If you feel like being ambitious, you can give your front yard an extreme makeover and make it into a show garden made up of all edible plants. Having a front yard that provides healthy, organic food but still looks beautiful can hopefully become the future of the American front yard.



8

Fig. 2.6 - Front yard edible landscape

## Community Gardens

A typical community garden is a large piece of land that is subdivided into plots and collectively gardened by a group of people. If you have a community garden in your neighborhood, you can join and be given a piece of land to garden on. The size of the plot varies, and you may have to pay a reasonable rent, but it can be worth it because you will most likely have access to free water, compost, fertilizer and tools.

If you are a beginner, you can also benefit greatly from becoming a part of a community of experienced gardeners. The advice that they can offer can be invaluable. If you find out that your neighborhood lacks a community garden, you can take initiative, find a vacant lot and start your own.



## Rooftop Gardens

An accessible rooftop can be the best site for an urban gardener. It may prove difficult to find a space in the city as ideal as a rooftop when it comes to space and sun exposure. However, you also have to deal with the fact that rooftops are often exposed to heavy wind, extra hot in summer and freezing cold in the winter. You also have to be sure that the roof can bear the weight of an urban garden, which can be heavy when you consider the weight of things such as pots and soil. Even with these potential downfalls, there are ways to plan and design rooftop sites so that they become successful, food-providing gardens.

9

Fig. 2.7 - Figure watering plant

# soil

If you are lucky enough to have space on the ground to grow in, it is necessary to first assess your soil before planting anything in it.



If you are living in the city, remember that your soil may be heavily polluted. Sources of contamination can range from toxic runoff from the streets to lead from stripped paint. You should get your soil tested by a certified testing lab to check if it is contaminated. However, the good news is that most lead levels in urban soils are usually not high enough to contaminate food grown on site. It is important to know what type of soil you have so that you can figure out what can grow best in it. Knowing your soil type also helps you prepare the ground accordingly to help overcome problems before they happen.

## Soil pH

The first step to determining what kind of soil you have is to figure out your soil's pH. Soil pH is a measure of the soil's acidity or alkalinity, and knowing the pH of your soil helps determine what you can grow in it. You can test your pH using an at-home test, which you can find at most garden or hardware stores. Many say that a soil with a pH that is neutral to slightly acidic is most preferred by food bearing plants. If your soil is not within this level, you can compensate by adding soil amenders such as compost or lime to bring the soil to neutral from either side of the spectrum.

### Garden Soil pH Scale

alkaline	pH 14	liquid drain cleaner
	pH 13	bleach
	pH 12	soapy water
	pH 11	ammonia solution
	pH 10	milk of magnesia
	pH 9	baking soda
	pH 8	sea water
	neutral	pH 7
pH 6		urine
acid	pH 5	black coffee
	pH 4	tomato juice
	pH 3	orange juice
	pH 2	lemon juice
	pH 1	hydrochloric acid
	pH 0	battery acid

10

Fig. 2.8 - Hand holding soil & pH Scale

## Soil Texture

### How to Determine your Soil Texture

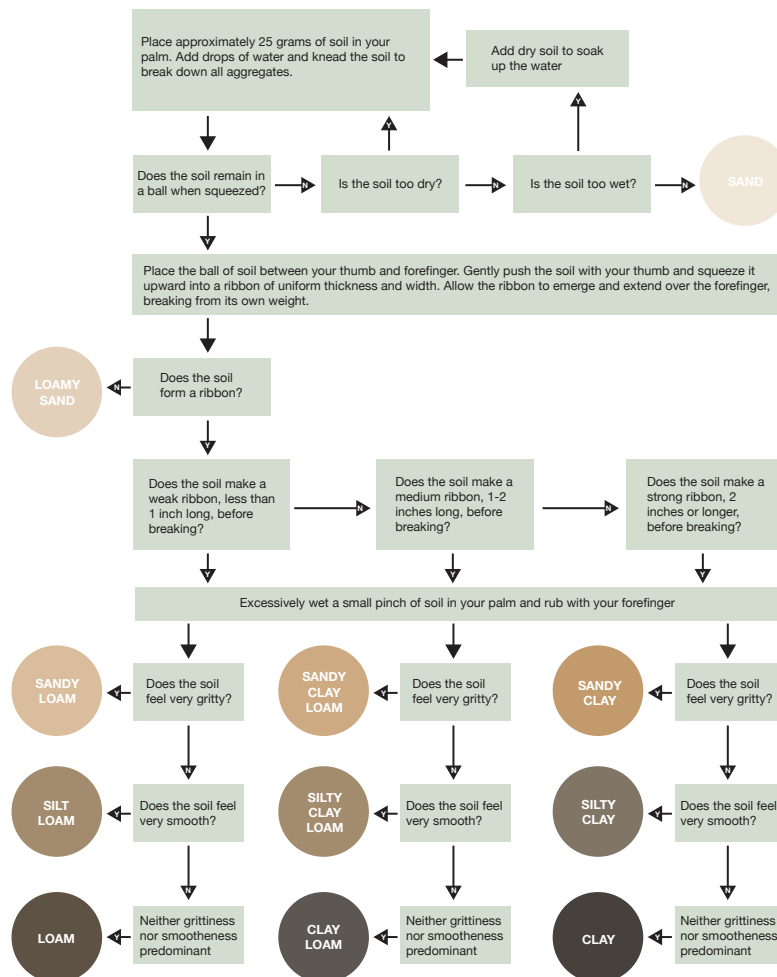

You should also determine your soil texture before planting. Soil is made up of three main components: sand, silt, and clay. The ideal soil has equal amounts of all three, but every other mixture has its own advantages and disadvantages as well as different plants that are suited for different soils.

Sandy soils are coarse and gritty. They consist of large particles and have large gaps between them. These gaps leave room for water and nutrients to flow through them, so they tend to be less fertile than clay and silt soils. However, they are good for growing root vegetables, such as carrots and rutabagas.

Clay and silt soils are smooth and sticky. They are made up of small particles. These soils are better at holding water and nutrients, but they can also become waterlogged. Brassicas and shallow rooted trees tend to grow well in these types of soil.

Fig. 2.9 - Soil texture flow chart

## Building & Protecting Your Soil

Soil is a living organism, and just like a plant, it carries out a cycle of life and death. Urban gardens tend to be small, and when growing in small spaces, you are forced to use your soil very intensely. Naturally, plants absorb nutrients from the earth and give some back when the plants die. This cycle continues again and again as long as there is no human intervention. However, when humans do intervene by planting other things in the same soil, this cycle is disturbed and it is our job to keep the soil alive. When we pull plants out of the ground at the end of the growing season, we also take away potential nutrition for the soil.

The quality of your soil directly relates to how well your crops will grow in them. It is important to remember that growing food depletes the soil over time, so you have to make sure that you are building your soil as you are using it. The best way to give back to your soil is to compost your yard and kitchen waste and add heaps of this compost to your soil once a year. Compost acts as a soil conditioner that can correct problems associated with your soil texture. It can help break up clay soils to improve drainage or bind together sandy soil to improve nutrient and water retention. Compost also helps return nutrients to your garden and is an invaluable resource.

Another way to build and protect your soil is to add mulch. Mulch is made up of materials such as leaves, bark, or straw, and it acts as a blanket that helps regulate soil temperature and retain moisture. It can also prevent weeds from growing and when it decomposes, it helps build the soil. Another added benefit of mulching is its aesthetic factor. Mulch has the ability to give gardening beds a little more structure and uniformity, which is important when trying to create an attractive edible garden.

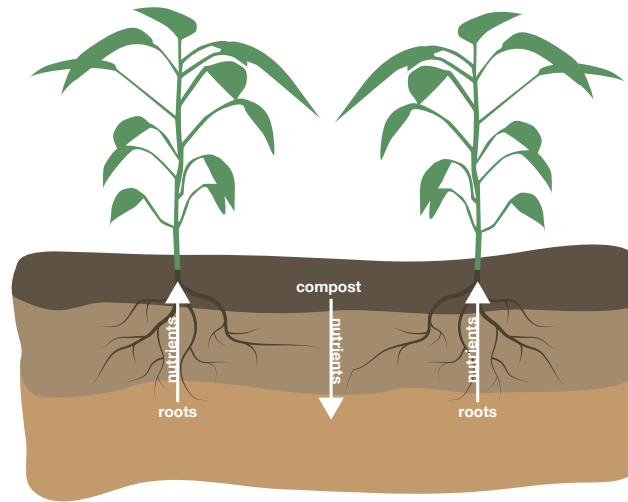

Fig. 2.10 - Soil nutrient exchange



## Crop Rotation

Crop rotation is key, especially when you are working with small amounts of land with quality that can quickly degrade. Each plant family absorbs different nutrients from the soil and attracts their own set of pests and diseases, so you should avoid planting the same thing in the same place all the time. By switching out your crops every year, your soil is given time to rejuvenate and pests are left confused. If you don't practice crop rotation, your crops will end up sucking up all the nutrients in your soil until nothing remains but a pile of dry, infertile dirt.

### How to Practice Crop Rotation

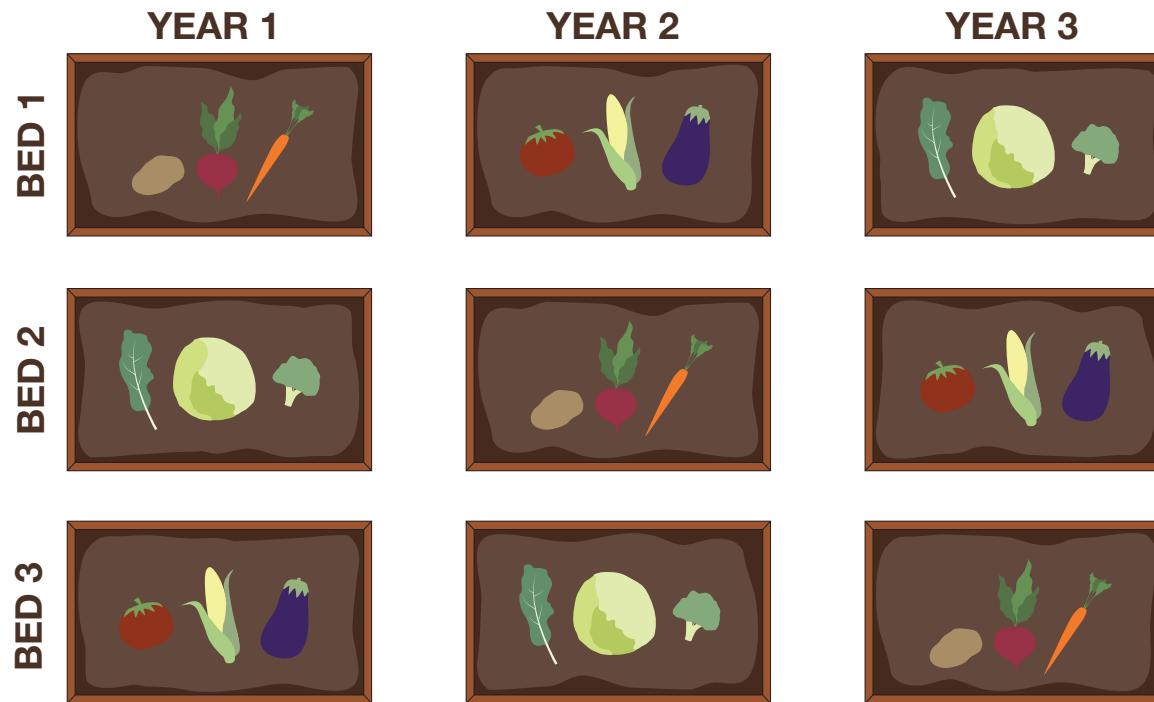

13

Fig. 2.11 - Diagram: crop rotation

# plants

Unfortunately, fruits and vegetables don't just fall from the sky. All things have a source of origin, and in this case, they are plants.

You can start your garden by planting seedlings from the nursery or by starting from seeds indoors. There are advantages and disadvantages to both methods. Some prefer skipping the seed stage and buying small plants from nurseries for instant gratification. When you skip the seed stage, your garden gets going faster and you can avoid the problems that sometimes come with starting from seeds. However, seeds are much cheaper than seedlings and while it takes a lot more patience to get your garden started, you may find it more fulfilling later on when you are eating vegetables that came from seeds that you planted yourself.

## Starting From Seeds

When it comes to sowing seeds indoors, you only need three things to start: a container, a growing medium, and seeds. When it comes to choosing a container, all you need is something that can hold soil and has drainage holes in the bottom. You can reuse old plastic containers from your recycling bin and just poke holes in the bottom, or you can buy seed sowing flats from your local nursery.

There are many germinating mediums available, such as peat moss, vermiculite, and perlite. These mediums are not usually used alone for germination, but in mixtures. Mixtures of peat moss, vermiculite, and perlite are generally the best mediums for germinating seeds. These mixtures are labeled as "seed starting mix" at the store, so you can purchase them ready made. If you will be using a lot of the mixture and want to save a little bit of money, you can purchase the separate mediums and mix them yourself.



14

Fig. 2.12 - Newly sprouted seedling

## How to Start Seeds

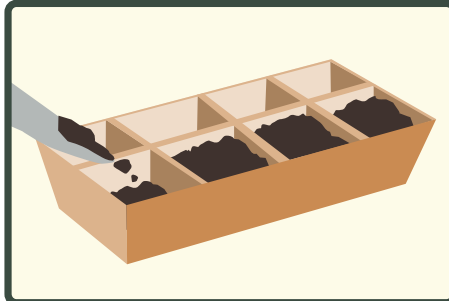

1. Fill your container with moist seed starting mix.

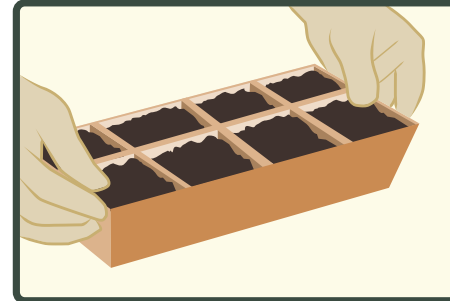

2. Once the container is filled, bang it on the table to make sure it is level

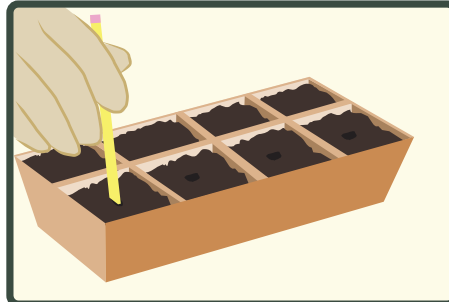

3. Make holes for the seeds by using a pencil or your finger.

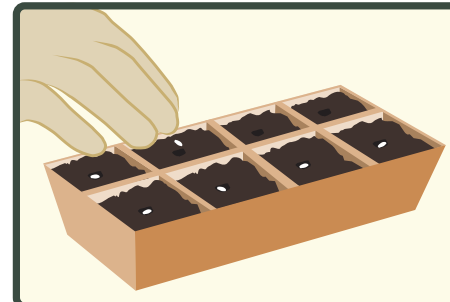

4. Drop your seeds into the holes one by one and cover them back up with soil.

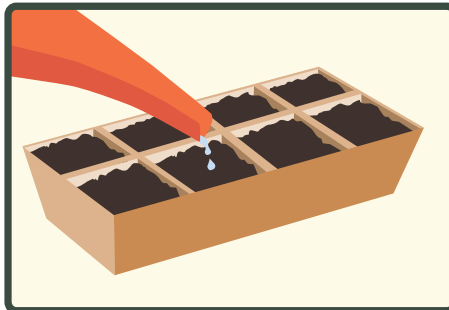

5. Gently water the soil in order to settle everything down.

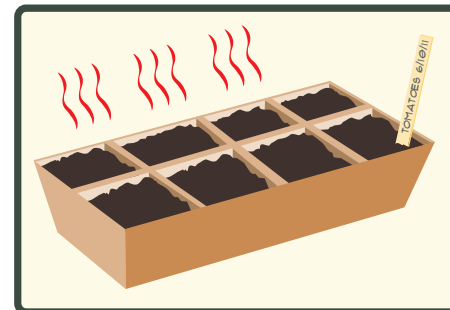

6. Label your containers and provide your seeds with warmth until they sprout.

15

Fig. 2.13 -Step by step: how to start seeds

## Hardening Off

After your seeds finally sprout, it is important they get a lot of light so that they can continue to develop. Supporting natural light with artificial light at night is okay. The right time to move your seedlings from container to the outdoors depends on the type of plant, but once your seedlings look sturdy enough, you can begin the hardening off process. Hardening off is a system of acclimating plants and transitioning them from the indoors to the outdoors. The reason transplants must go through this process is so that the plants do not die from shock or irregular growing conditions when planted into the ground. You can start this process by setting your seedlings outside in a sheltered spot during the day, then bringing them back in at night. You can gradually extend their time spent outdoors until you can finally start leaving them outside permanently.

## Transplanting

When transplanting seedlings (homegrown or store bought), it is best to try to preserve the soil around their roots as you are pulling them out of their containers. When plants have been in containers for too long, their roots begin circling around the container looking for a place to go. When the circling roots almost create a pot themselves, the plant is called "root bound." Root bound plants should not be planted as is, because they will not be able to spread their roots and may end up strangling themselves. Therefore, you have to help the plant by loosening up the roots.

### How to Break up Root Bound Plants



1. Tease the coiled roots, trim off the large, thick roots and keep the new, healthy looking roots intact.

2. Gently break up the remaining roots to help promote future growth.

Fig. 2.14 - Step by step: how to break up root bound plants

## How to Transplant Seedlings



1. Seedlings are ready to be transplanted when they have at least two sets of true leaves and roots that are exposed.



2. Prepare your planting surface by shoveling a layer of compost onto your soil. Mix the compost into the soil and flatten the surface.



3. Use a shovel to dig a hole about twice the width of the rootball and set the plant into the hole so the rootball will be covered by about 1/4 inch of soil.

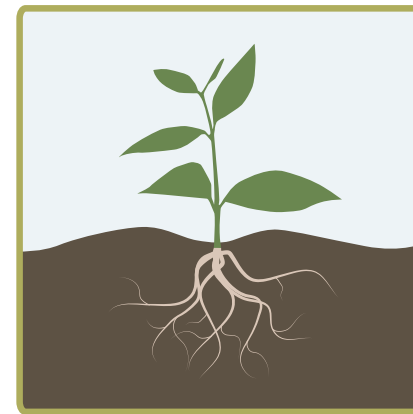

4. Firmly press the soil around the rootball and form a shallow basin around the base of the plant.

17

Fig. 2.15 - Step by step: how to transplant seedlings

# planting in small spaces

When working in urban conditions, it is important to take advantage of whatever space you have available to you.

The positioning of plants in your garden is very important. When plants are placed too close together, they end up competing for nutrients, light, root space, and surface growing space. Spacing plants too far apart doesn't necessarily hurt the plants, but it can lower your harvest yield. Since you are not making use of all the available space, productivity is lowered. A common technique used in smaller spaced gardens is growing your plants in groupings rather than rows. This way, you can fit more into a tight space without making plants push up against one another.

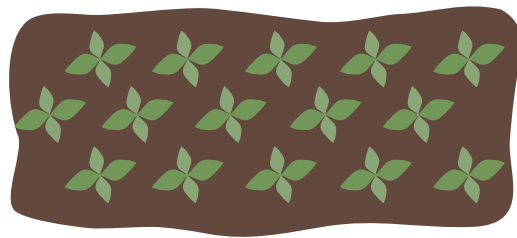

Groupings

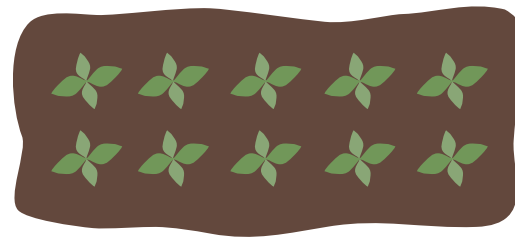

Rows

## Companion Planting

Companion planting is another great technique that can be utilized in smaller spaces. The idea is that by planting different crops in proximity, the plants can help each other reach certain goals, such as increased crop productivity, increased nutrient uptake, pest control, and pollination. The combination of different types of crops within the same space also makes for a more varied, attractive garden and a better use of limited space. While there are many companion plants that you should try to group together, there are also some combinations that you should avoid.

18

Fig. 2.16 - Diagram: groupings vs. rows

## How to Practice Companion Planting



\*see p. 33 for key

19

Fig. 2.17 - Diagram: companion planting

## Raised Beds

In urban environments, you can skip the headache of working with possibly contaminated soils by building raised beds. Though a raised bed is basically just a bottomless box that holds soil, it provides many benefits that help your garden become more productive. Raised beds keep the soil warm and provide excellent drainage. The soil inside also stays rich and light, as it never gets compacted from being stepped on. Finally, they are easier to work with because you are not forced to bend over as much.

Raised beds can be made in any shape or size, and from any material that can hold water. Using new, good quality wood will be the best in standing up against the elements, but it will also be the most expensive. If you do choose to buy wood, you should use rot-resistant and sustainably harvested wood, and avoid using treated wood. Otherwise, you can use wood from old pallets, cinder blocks or even pieces of broken up concrete. Just know that these beds may not last as long, and you may need to patch them up once in a while.

### How to Build a Raised Bed

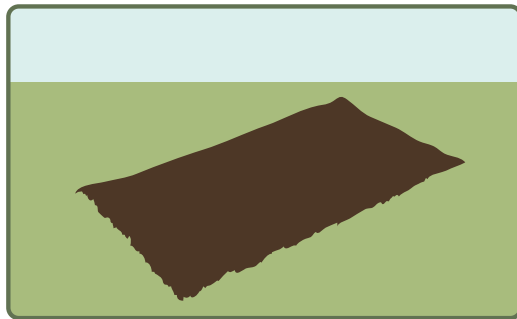

1. Choose a spot that gets a lot of sun. Mark the dimensions of your bed and if there is sod, dig it out. Use a level to make sure the ground is completely flat.

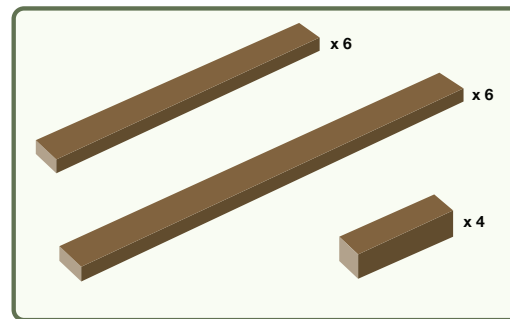

2. Using a circular saw, cut the 2x4s and the 4x4 to the appropriate lengths.

Fig. 2.18 - Step by step: how to build a raised bed



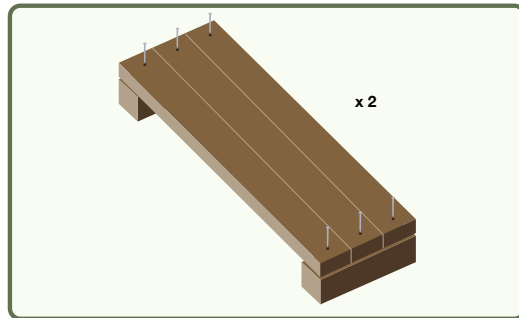

3. Secure the 2x4s to the 4x4s and make sure that they are flush to the top of the post and even and square on the sides. Attach the 2x4s with screws, and secure the posts on the other end the same way.

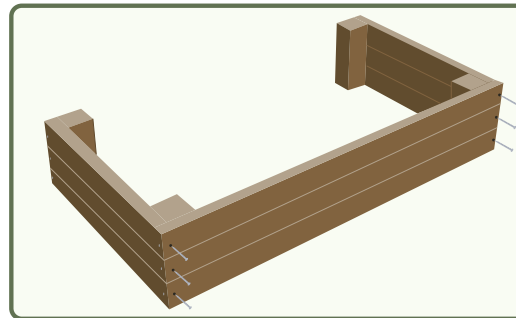

4. Attach the longer 2x4s with screws to both sides to finish off the bed.

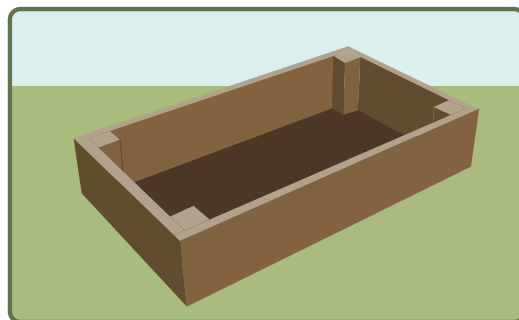

5. Set the box in place and make sure that it is level.

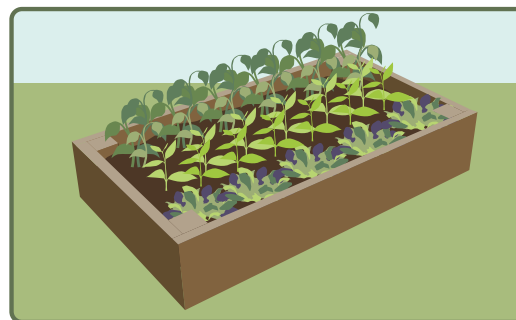

6. Fill the container with soil and add plants.

Fig. 2.19 - Step by step: how to build a raised bed (continued)

## Containers

If you don't have any space to grow crops in the ground, most of your plants will be growing in containers. The good thing is that pretty much anything can grow in a container (though not always with as high of a yield as in-ground plants). You can also hang containers to maximize space in your garden. Another great thing about planting in containers is that the soil use will be fresh, unlike the unhealthy soil you may be cursed with in your backyard.

When putting soil in your containers, be sure to fight your instinct and avoid taking soil from the ground. You need to purchase potting soil, or container mix, which is a soil like substitute that has the ability to hold moisture well and drain freely. This will help crops grow to their maximum potential.

Anything that can hold soil can be used as a container, so container gardening is the perfect opportunity to save money and help reduce waste by reusing old household items that were destined for the landfill. Buckets, tin cans and even old dresser drawers can be used to grow plants in. As long as you drill a few drainage holes into the bottom of a container, it can be used to grow food. However, you should exercise caution when using plastic containers. Some are made from chemicals that can break down from heat or just over time, leaching into your soil and contaminating your food. It is important to know which plastic is okay for growing food and which isn't.

### How to Turn Household Items into Containers



1. Find an old household item that is large enough to hold soil.

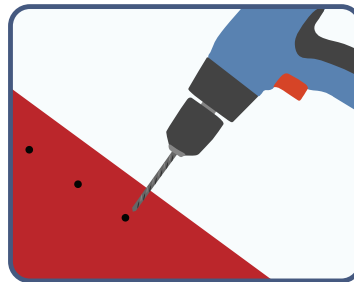

2. Use a drill bit to make several drainage holes in the bottom of the container.



3. Fill with soil and plants

Fig. 2.20 - Step by step: how to turn household items into containers

# maintenance

Once you have everything planted where you want it, the real work begins. It is important to nurture your garden so that it can provide you with bountiful harvests.

## Watering

Water is a precious resource that we should always try to conserve. Therefore, it is important to know when and how to water your plants. All plants are different, and the daily conditions in which they live in are always changing, so there is no set schedule that everyone can follow. However, there are some things you can keep in mind when watering. Clay soils hold more water, so they don't need to be irrigated as often as sandy soils. Recently transplanted plants need more water while getting established, and plants in containers tend to dry out quickly, so they need to be watered almost every day.

Though you may not know it, there actually is a way to water incorrectly. Over watering plants can cause rot or contribute to the growth of shallow roots. Plants that are under watered will suffer from drought and eventually burn to a crisp. The best thing to do is to water the plants directly and make sure the water penetrates straight down into the roots. Watering deeply will give the roots a nice supply of deep soil moisture. It is best to avoid watering during the heat of the day, because this can lead to scorching of the leaves. You should also be sure not to direct a strong stream of water towards the base of a plant, as this can wash soil away from the roots and prevent the water from finding its way down into the soil. Finally, you should avoid wetting the leaves, as this can contribute to rot and fungal diseases.

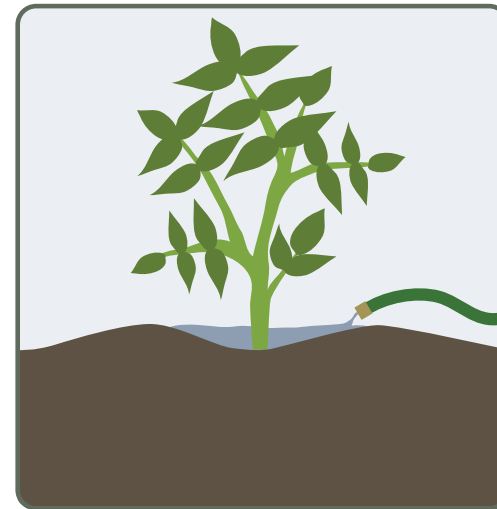

23

Fig. 2.21 - Plant being watered

## Natural Fertilizers

Nitrogen, phosphorus, and potassium are the three most important nutrients that help regulate plant development. These can be found in various ratios in both organic and non-organic fertilizers. The difference is that non-organic fertilizers are man made with chemical compounds, and organic fertilizers are made of natural things that were once alive. Nitrogen, phosphorus, and potassium contribute to plant development in different ways.

Nitrogen helps plant growth, and while plants usually need a lot of it, they can easily get too much. An overdose of nitrogen can cause the plant to grow leafy and lush quickly, stealing the nutrients away from flowers and fruits. It can also cause plants to grow tall and feeble, making them unable to support heavy fruits and vegetables. Nitrogen can be found in blood meal, feather meal, fish emulsion, worm castings, and compost. Growing cover crops such as beans or other legumes can also help produce nitrogen in your soil.

Phosphorus helps produce strong root systems that provide the means for growth. Plants without enough phosphorus tend to grow very slowly and have stunted roots, so it is important that root crops get enough of it. Rock phosphate, bonemeal and compost can help contribute more phosphorus into your soil.

Potassium helps plants make fruit and makes the plant itself more vigorous and resilient. It can also help stave off disease. Potassium can be found in Greensand and wood ashes.

There are several fertilizers that you can build yourself from combining different organic sources of Nitrogen, phosphorus and potassium. When fertilizing, it is important to know that it is possible to add too much fertilizer to your garden. Overfertilized plants are prone to illness and disease, so it is best to be conservative when fertilizing your plants.

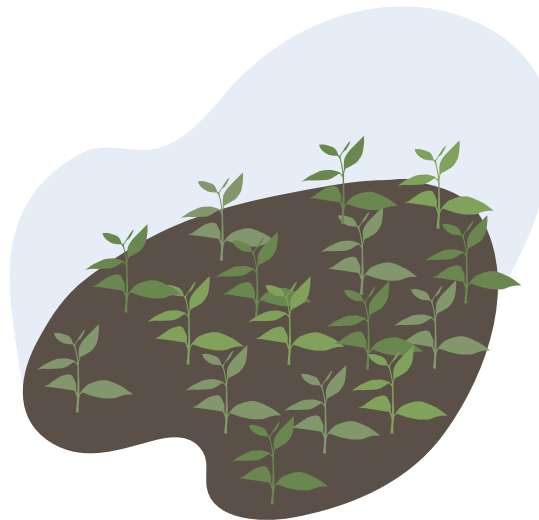

Fig. 2.22 - Grouping of plants

Gardens that are regularly weeded have been proven to be more productive than unweeded ones. Therefore, it is important to know how to deal with weeds in your garden. Weeds compete with plants for sun, nutrients, water, and root space. The most efficient way to deal with weeds is to prevent them from invading from the start.

Weeds are opportunists, so they will take whatever space on the ground they can get whenever they get the chance. The best way to keep them from growing is to implement techniques that take away the space and light that weeds require to grow.

### How to Prevent Weeds from Growing



Apply an organic mulch such as bark, leaves or straw to help prevent weed germination and growth.

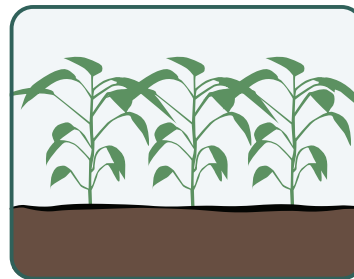

An inorganic mulch, such as black plastic, can also be applied to prevent light from getting to weeds.



Plant densely growing plants close together so that there is no space for weeds to grow.

Weeds are invasive, so when you see them it is best to act promptly. The simplest and most natural way to rid a garden of weeds is to do it by hand. Weeds can be pulled or removed using hand tools. Small hand tools such as asparagus knives and trowels are very effective on small weeds, but you are limited to working on your knees. A tool that allows the gardener to stand while removing weeds is the stirrup hoe, which is lightweight and very effective. It is best to remove weeds regularly so crops do not have to compete.

Fig. 2.23 - Diagram: weed prevention

## Composting

Composting is a great way to reduce your waste and create something that can contribute to your garden. Composting transforms your kitchen scraps, yard waste and other things you would otherwise toss into the trash or recycling bin into new soil. Compost can provide your soil with several benefits, such as improved texture, higher nutrient content and better drainage capabilities. All you need to start composting is a patch of ground large enough to set a garbage can on.

You can construct a composting bin by using found materials such as wooden pallets, chicken wire or straw bales, but the simplest thing to do is to punch a few holes into a lidded garbage can. The holes provide the compost with air circulation and reduce stench.

If possible, set your bin on top of soil, then punch large holes of about ¼" into the bottom of your bin in order to allow beneficial critters such as worms in. If you have to set your bin on concrete, keep it on top of a tray or some sort of catchment basin in order to catch all the liquid that oozes out of it. This liquid is full of nutrients, and can be used as a fertilizer for your plants.

Once you have a bin, you can begin composting by tossing your kitchen scraps and yard waste into it. In order to keep an effective pile, it is important to keep a good balance between nitrogen-rich material, or "greens," and carbon-rich material, or "browns." Greens are considered wet material, and include materials such as fresh leaves, used herbivore pet bedding, and kitchen scraps. Browns are dry, and consist of dead materials such as dried leaves, wood and shredded newspaper. It is usually easy to separate waste into browns and greens.

Since composting needs air to keep working, you can turn your compost piles a few times a week by mixing it around with a shovel. This speeds up decomposition and keeps your pile alive. Finished compost is dark and crumbly with an earthy smell. If you find any identifiable objects in your pile, then that means your compost isn't ready yet. You can separate finished compost from stuff that's still in the process, and use what is ready on your garden.

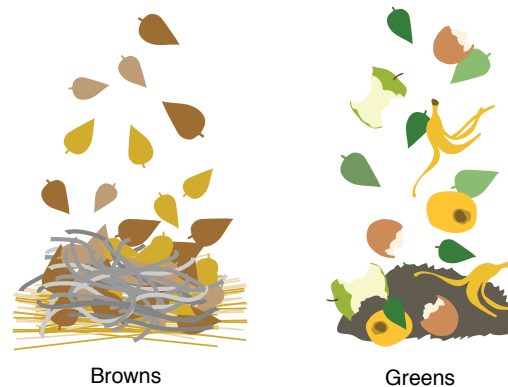
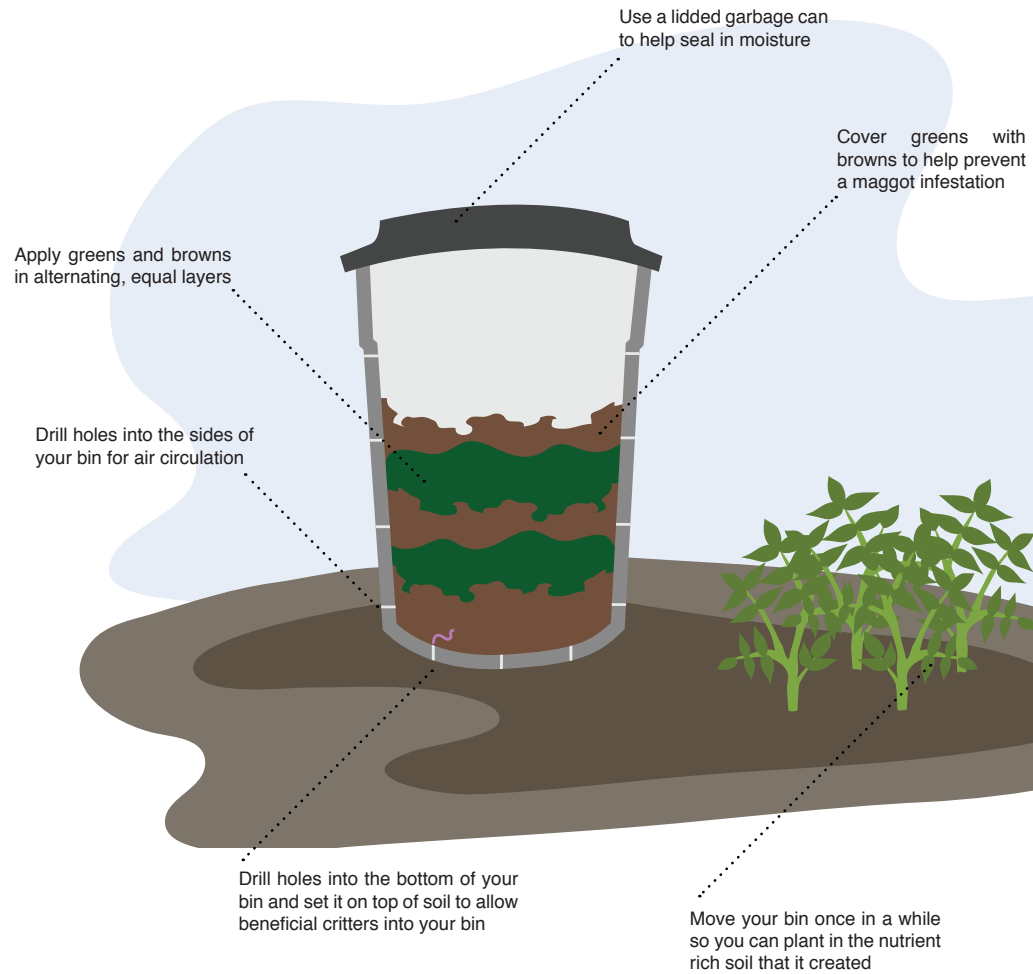

Fig. 2.24 - Browns and greens for composting

## How to Compost with a Garbage Bin



27

Fig. 2.25 - Composting diagram

## Vermicompost

Worm bins are perfect for those living in tight spaces who still want to compost. A basic worm bin is just a box filled with shredded newspaper, a little bit of soil as a starter, kitchen scraps and worms. Be sure to place a tray below the box to catch any moisture that may seep out. Worms will eat your kitchen scraps, and replace them with worm castings, or worm poop. These castings are packed with nutrients and beneficial microbes and bacteria, and can be applied directly around the base of plants or mixed into the soil.

You should feed your worms any non-meat organic waste, such as vegetables, fruits and coffee grounds. Break down large scraps into smaller pieces so that they break down easier, and make sure you do not feed them any fats, dairy products or meat. In order for your worm bin to be successful, you have to have the right type of worms. Redworms, or red wigglers are the best types of worms for composting.

Vermicompost systems can be placed anywhere inside your home and work best at room temperature. You can begin harvesting your compost after about three or four months.

### How to Compost with Worms

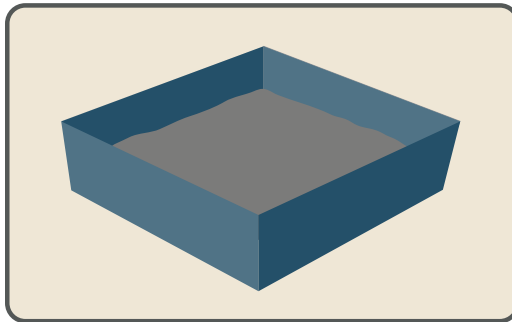

1. Place shredded newspaper into the bottom of your box and dampen with water until you have a 6-inch layer of damp paper.

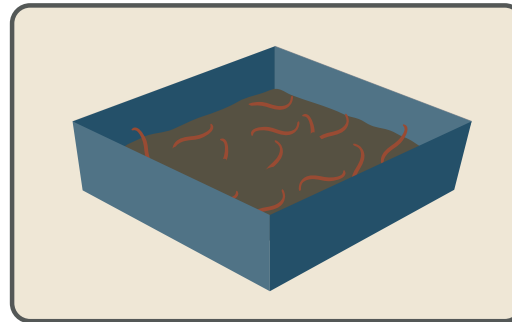

2. Mix in a couple handfuls of soil and gently place your worms into the bedding.

Fig. 2.26 - Step by step: how to compost with worms



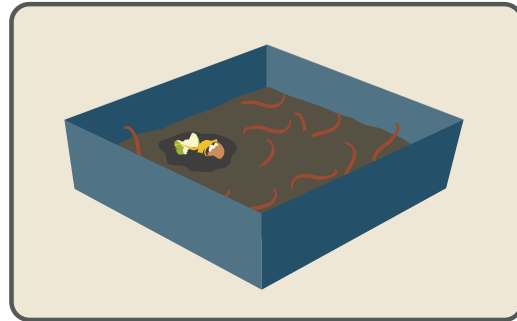

3. Feed your worms by digging a hole into the bedding and filling it with a handful of kitchen scraps. Cover the scraps with bedding.

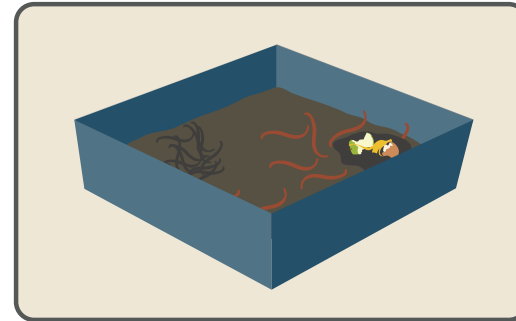

4. After about a week, add food again into a different part of the bin so that the worms move and leave behind their nutrient filled castings.

Worm castings are packed with minerals and can contribute greatly to plant growth. It can be mixed into soil and used for germination, giving newly planted seedlings a jump start. It can also be added as a soil conditioner to encourage growth, or it can be spread directly around the base of a plant, where it can act as an additive for trees and vegetable plants. Worm castings also have many other benefits. They have the ability to fight off plant diseases and fix heavy metals in organic waste. They also act as barriers to help plants grow in a soil where the pH levels are too high or too low. Finally, worm castings form aggregates in soil, so they help increase water retention and are able to withstand water erosion and compaction. Worm bins are able to provide small space gardeners living in the city with all the benefits of composting.

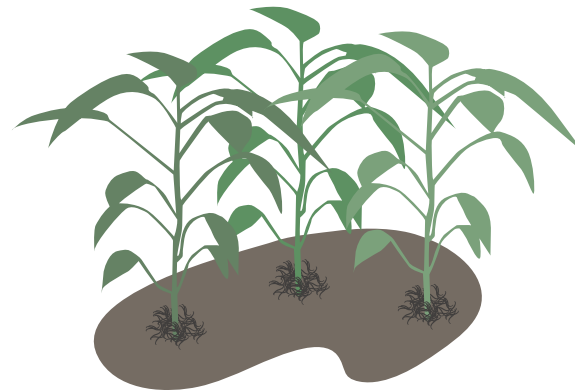









29

Fig. 2.27 - Step by step: how to compost with worms (continued)

## Pests & Diseases







An organic garden will never be completely pest or disease free. The only way to achieve a completely sterile garden is with chemical pesticides, but in addition to removing bad pests and disease, they also wipe out helpful organisms that can contribute to the garden. You must recognize that pests and disease will be present, but they can be prevented from taking over your garden by using a few organic techniques. Identifying the problem is the most important step in keeping your garden from becoming infested with pests and diseases.

### How to Deal with Pests and Diseases

Symptom	Cause	Cure	Plants Affected
Clusters of small green insects on plants, sticky secretions and curled leaves	 Aphids	Spray them off leaves with water, and grow plants in the onion family to ward them off and attract aphid predators such as ladybugs and spiders.	All garden vegetables
Irregular holes in foliage	 Cabbage Worms & Butterflies	Handpick the worms off the leaves and apply a floating row cover on your crops to keep adult moths from laying their eggs in your garden.	
Chewed foliage, clusters of orange eggs under leaves	 Colorado Potato Beetles	Remove by hand and plant garlic nearby to help repel beetles and encourage predators.	
Chewed leaves, flowers, stems, roots and sometimes young fruit	 Cucumber Beetles	Inspect plants frequently and remove by hand. Mulch plants with a thick layer of straw to block larvae from emerging from the soil.	
Entire plant cut off at the base	 Cutworms	Protect newly planted seedlings with a cutworm collar: anything that can be fashioned into a tube (such as a toilet paper roll) that can protect the base of a plant.	

30

Fig. 2.28 - Chart: pest and disease management

Symptom	Cause	Cure	Plants Affected
Slime trails and irregular holes in leaves and lower stems	 Slugs and Snails	Collect them every morning by employing traps. Shallow containers of beer will attract and drown these pests.	
Leaves and fruits eaten	 Tomato Hornworm	Check plants regularly and remove caterpillars by hand and plant basil nearby to help repel them.	
Misshapen, deformed roots, and wilted plants	Clubroot	Clubroot mostly infects plants grown in acidic soil, so amend your soil with lime, practice crop rotation and keep brassicas out of previously infected soil.	
Yellow spots on leaves that may also be twisted and deformed	Cucumber Mosaic Virus	Since it is brought on by aphids, encourage aphid predators such as lady beetles in your garden. Once the plant is infected, CMV cannot be stopped, so remove the plant from the site and practice crop rotation the following	
Gray and white powder on leaves and flowers	Mildew	Avoid spraying leaves with water and prune back dense foliage to facilitate better airflow.	

When searching through your garden for pests, be careful not to accidentally kill insect predators. You do not want to get rid of predators that may actually be keeping pests out of your garden. The simplest way to get rid of pests that have already established themselves on your site are to pick them by hand and kill them quickly and humanely. Once you identify the pests and remove them the first time, there are ways to keep them from coming back.

Beneficial insects can be introduced to your garden simply by planting flowers that they are typically attracted to. These insects act as predators for the unwanted critters in your garden. During egg-laying season, you can cover newly planted transplants with row covers to keep adult pests from flying around them and laying eggs on delicate leaves. You can use these techniques for controlling pests and diseases in order to help keep your garden healthy and productive.

Fig. 2.29 - Pest and disease management chart (continued)

# harvesting

The hard work all pays off when it is finally time to harvest.

It can be tricky knowing exactly when your produce is ready to harvest, but most of it is actually just a mixture of basic instinct and trial and error. If you are growing things that you are already used to eating, harvest them when you know they are ripe. Try harvesting your vegetables at their peak, because the more you pick, the more your plants will produce.











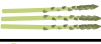











Harvest times vary from plant to plant and sometimes among varieties of plants, so it is important to get to know each crop's life cycle. There are some general harvesting techniques that can apply to many of your crops, but you will learn the most through experience. The best thing to do is allow yourself to make mistakes and learn from them for future reference.



32

Fig. 2.30 - Harvesting basket

## Harvesting Chart

Vegetable	When Can I Harvest?	Jan	Feb	Mar	Apr	May	Jun	Jul	Aug	Sep	Oct	Nov	Dec
 Asparagus	Spears are about 6-8 inches tall												
 Beans	Before you can see the seeds bulging												
 Beets	Once the top of the beet begins protruding at the soil line												
 Broccoli	The buds are about the size of a match head												
 Cabbage	The head is solid when gently squeezed												
 Carrots	The top of the carrot protrudes the soil line and the diameter looks right												
 Cauliflower	The head looks full												
 Chard	After five leaves have developed												
 Corn	Three weeks after the silks form and they turn dry and brown												
 Cucumbers	Fruit is firm and smooth												
 Eggplant	Fruit is firm and shiny												
 Garlic	Once the tops fall over and begin to brown												
 Lettuce	The head feels full and firm when gently squeezed												
 Onions	Once the tops have ripened and fallen over												
 Peas	Pods look and feel full												
 Peppers	Fruit feels firm and crisp												
 Potatoes	Once the tops start to flower												
 Radishes	Once the tops of the radishes begin protruding at the soil line												
 Spinach	Before you see a flower stalk beginning to shoot up												
 Summer Squash	Skin is tender enough to poke a fingernail through												
 Winter Squash	Once the color looks right												
 Tomatoes	Fully colored and slightly soft to the touch												

33

Fig. 2.31 - Harvesting chart

# prototype designs

By combining good design with urban agriculture, we can create beautiful sites that give back.

These prototype designs are meant to give you an idea of how you can combine all the techniques learned throughout this guide and practice them on the site of your choice. Prototype designs for a balcony, front yard and a community garden provide design ideas for those of you who would like to create your own beautiful, productive gardens.

## Balcony Design

When designing an edible garden for your balcony, many factors have to be considered. Wind and sun are two issues that may be brought up when planting on a balcony, so make sure you take appropriate measures to protect your plants from possibly harsh conditions. Since the space is confined, it is very important to use what you have in unconventional ways. To get the most out of your small space, you should grow plants that grow in a variety of ways: low growing plants, climbing plants and plants that can grow in hanging containers. This also helps with the aesthetic appeal of your balcony, as it gives it a lush, full look. You can get creative with containers to maximize space, but it is also important to keep the weight of the containers manageable. Do not forget that you are putting heavy plants and soil on a cantilevered surface, so you do not want to stress the structure too much. Finally, it is important to be aware of how you are watering your balcony garden. Consistent watering is essential for container plants. You also should be aware of how your water drains, because your downstairs neighbors may not appreciate water trickling off of your balcony and onto theirs.

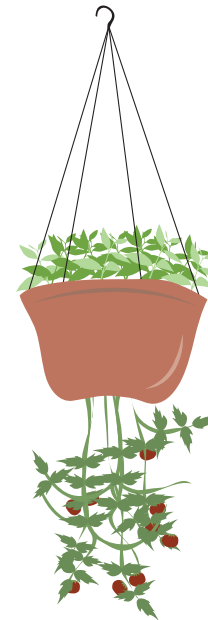

34

Fig. 2.32 - Hanging tomato plant

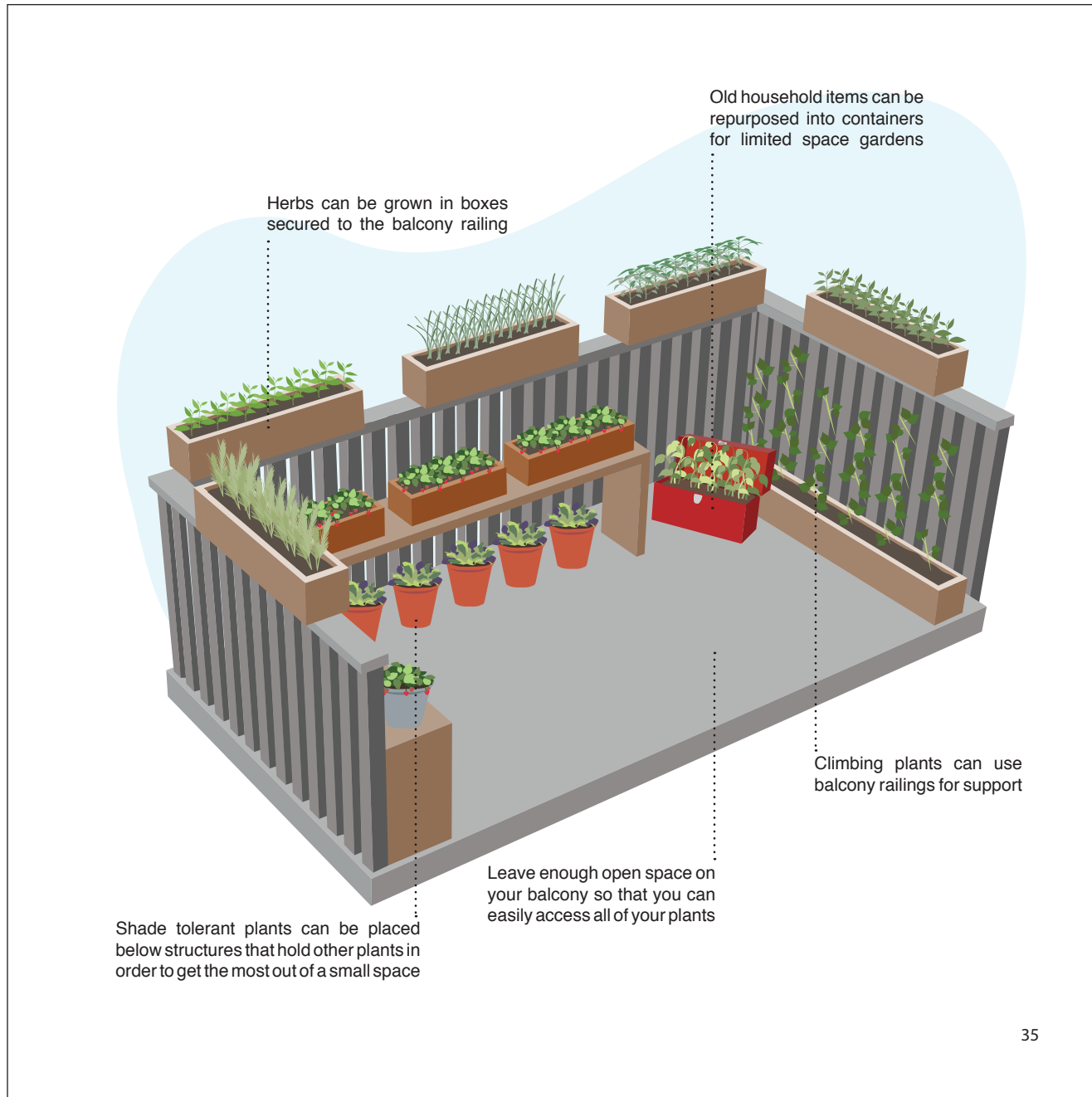

Fig. 2.33 - Balcony prototype design

## Front Yard Design

Many front yards generally have good solar access, are relatively flat and are very visible from the street, so they act as perfect sites to implement urban agriculture that have the power to be productive, beautiful and educational to homeowners, neighbors, and casual passersby. These types of urban gardens offer a lot of flexibility, but they also seem to be the most controversial. Some traditional neighbors may not appreciate you tearing out your pristine green lawn and replacing it with an “unruly” vegetable patch, so it is important to break this expectation and focus on making your productive garden a beautiful one also.

You can implement edible landscaping into your existing landscape to be subtle, or you can rip everything out and start from scratch, creating a show garden made up of all edible plants. Either way, by redesigning your front yard, you are breaking the mold of the traditional front yard and hopefully influencing the future of the American suburb.

36

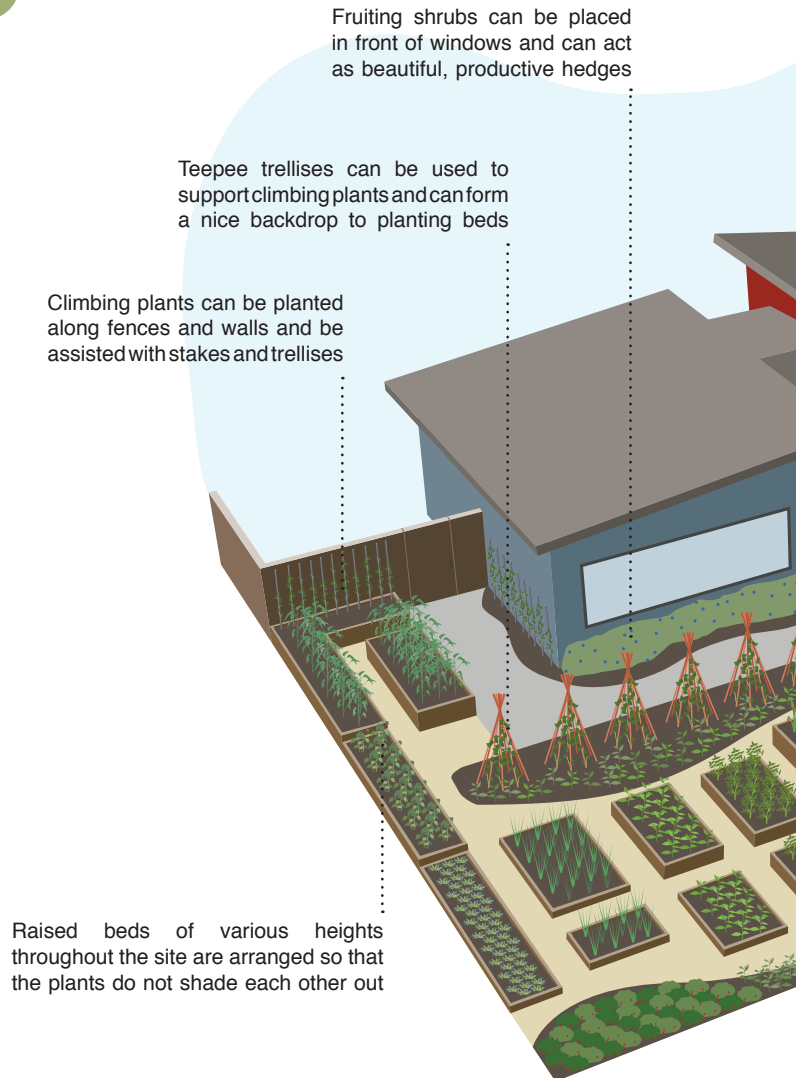
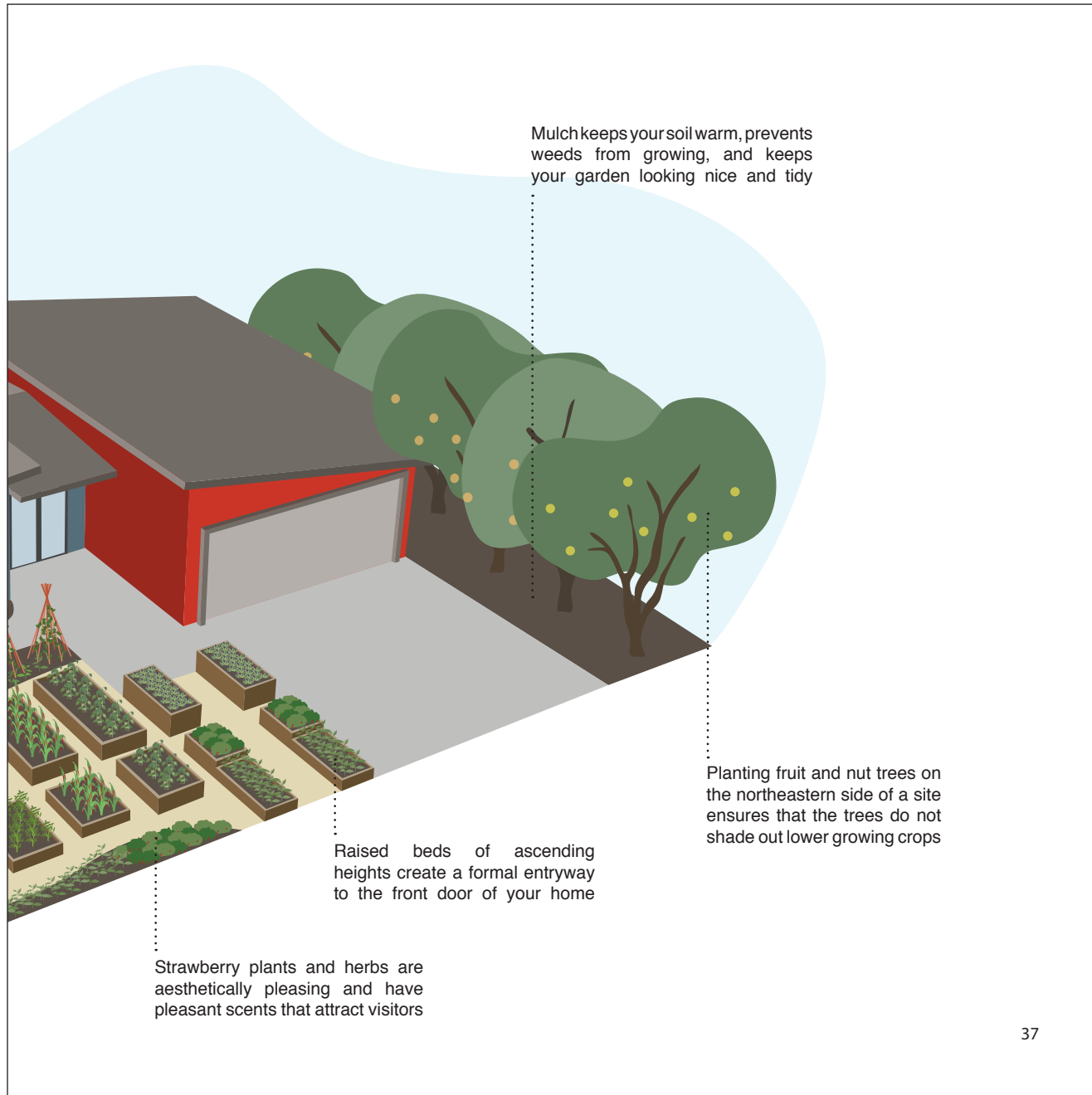

Fig. 2.34 - Front yard prototype design (see p. 62 for full graphic)





Mulch keeps your soil warm, prevents weeds from growing, and keeps your garden looking nice and tidy

Planting fruit and nut trees on the northeastern side of a site ensures that the trees do not shade out lower growing crops

Raised beds of ascending heights create a formal entryway to the front door of your home

Strawberry plants and herbs are aesthetically pleasing and have pleasant scents that attract visitors

## Community Garden Design

The abandoned lots in cities can be reclaimed by community gardens. Community gardens tend to fall into a few categories. There are those where land is subdivided into individual plots and gardeners are given a space to plant, and there are those where a community works on the entire garden as a team. I believe that the latter breaks away from traditional community gardens, so I would like to expand on that by creating a prototype design for what I would call a "Community Building Garden."

This design focuses on different activities that could occur within a community garden, such as meeting and relaxing spaces. It also focuses on being aesthetically pleasing so that it can stand as a good example to passersby that not all community gardens are unattractive. People like things that look good, so making productive gardens beautiful will help them become more widely acceptable.

Composting on site allows you to repurpose your waste and use the generated soil in your garden

A garden shed tucked away in the corner of your site helps keep your tools neatly organized and easily accessible

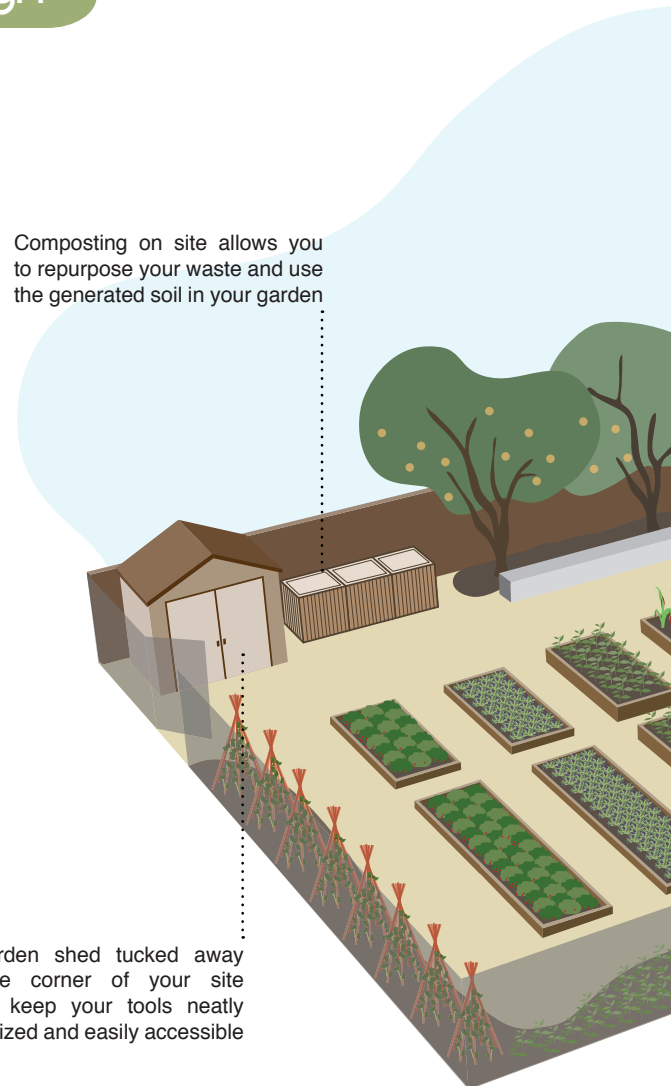
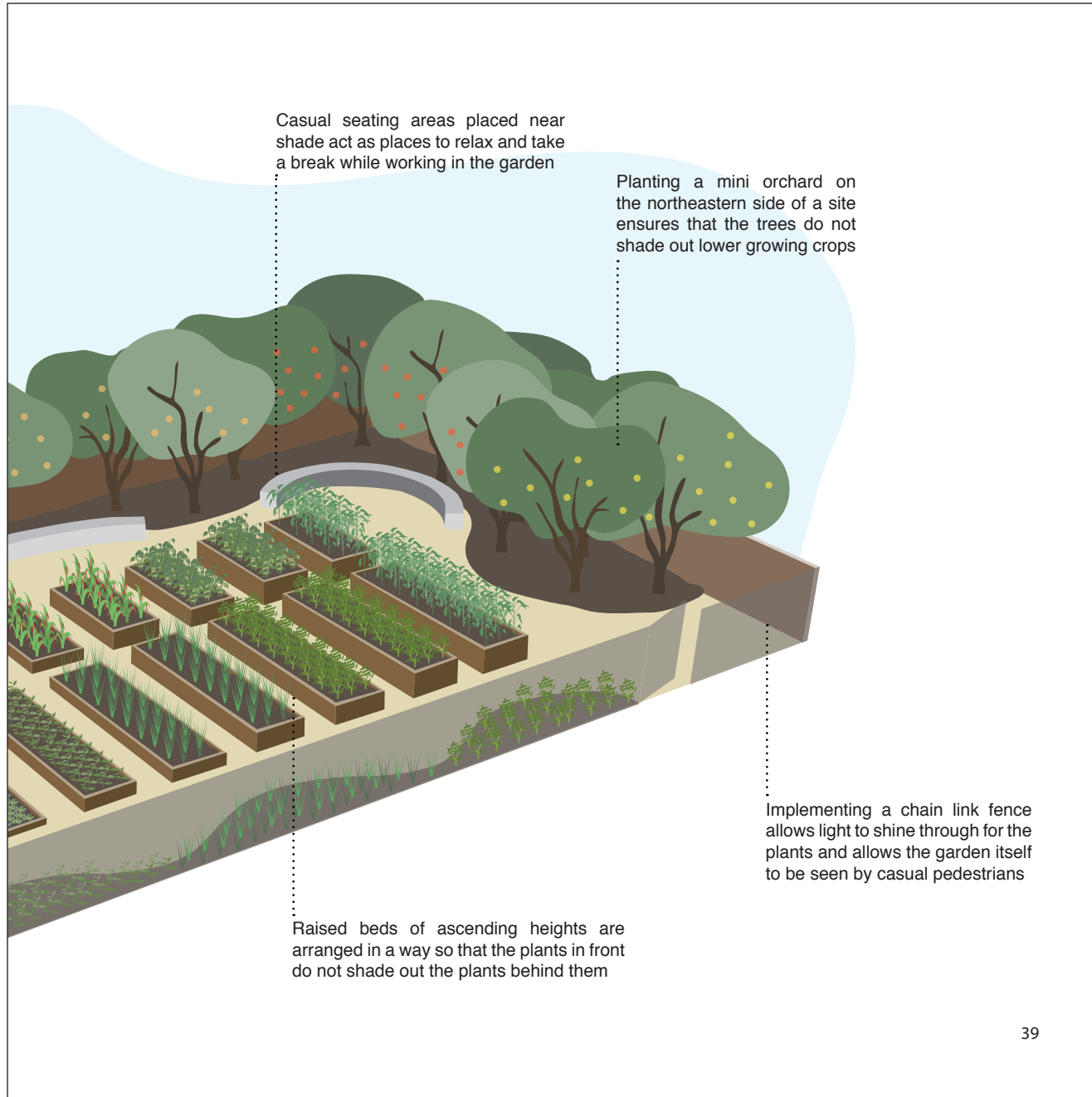

Fig. 2.35 - Community garden prototype design (see p. 63 for full graphic)



Casual seating areas placed near shade act as places to relax and take a break while working in the garden

Planting a mini orchard on the northeastern side of a site ensures that the trees do not shade out lower growing crops

Raised beds of ascending heights are arranged in a way so that the plants in front do not shade out the plants behind them

Implementing a chain link fence allows light to shine through for the plants and allows the garden itself to be seen by casual pedestrians

# sources

## community gardening

American Community Gardening Association ([communitygarden.org](http://communitygarden.org))

## edible landscaping

*Edible Estates: Attack on the Front Lawn*, Fritz Haeg (2010)

*Grow Great Grub: Organic Food from Small Spaces*, Gayla Trail (2010)

*The Backyard Homestead*, Carleen Madigan (2009)

*The Urban Homestead*, Kelly Coyne and Erik Knutzen (2010)

## food security

*Public Produce*, Darrin Nordahl (2009)

*Food and Fuel*, Andrew Heintzman and Evan Solomon (2009)

## graphic design

*Show Me How*, Derek Fagerstrom, Lauren Smith & the Show Me Team (2008)

*The Visual Miscellaneum*, David McCandless (2009)

## urban agriculture

*CPULS: Continuous Productive Urban Landscapes*, Andre Viljoen, Katrin Bohn and Joe How

Fig. 2.36 - Sources

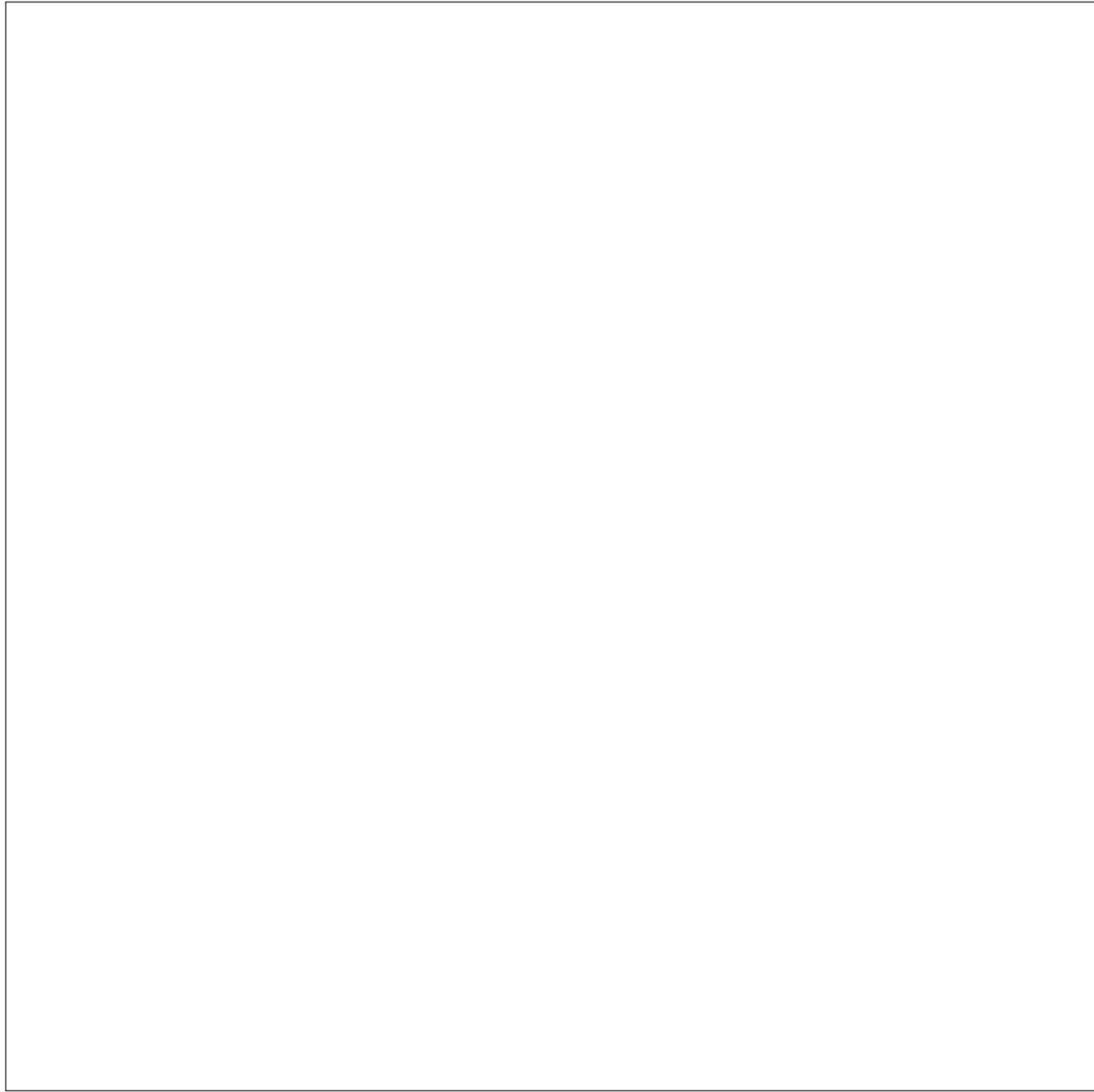

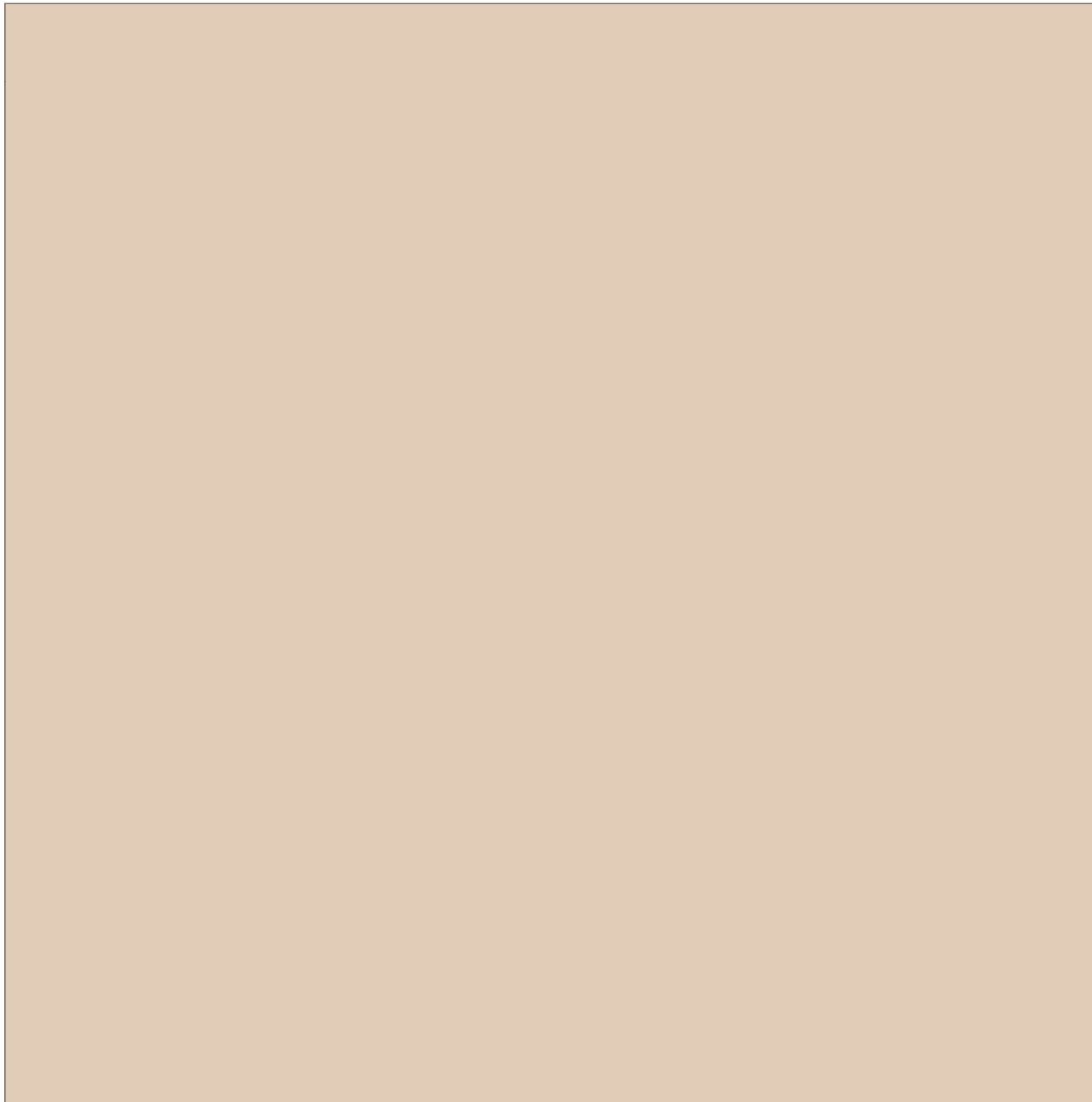

*Fig. 2.37 - Back cover*

# conclusion

Making urban agriculture more prominent in America can help our society advance socially, economically and environmentally. It can bring people together, help us become healthier, and teach us how to utilize wasted space in cities. I created this guide in order to make urban agriculture more accessible and hopefully spark a newfound interest in readers. My hope is that one day urban agriculture will be seen as a commonality and not an occasional novelty, and I believe that the guidebook I created and its simple graphic style has the potential to finally bring urban agriculture into the mainstream.





# BIBLIOGRAPHY

- Burros, Marian. "Obamas Prepare to Plant White House Vegetable Garden - NYTimes.com." The New York Times - Breaking News, World News & Multimedia. 29 Apr. 2011. Web. 29 Apr. 2011. <<http://www.nytimes.com/2009/03/20/dining/20garden.html>>.
- Coyne, Kelly, and Erik Knutzen. The Urban Homestead: Your Guide to Self-sufficient Living in the Heart of the City. Port Townsend, WA: Process Media, 2010. Print.
- "GrowGuides: Soil Types." The Smart Way to Plan Your Garden. Web. 29 Apr. 2011. <<http://www.growveg.com/growguides/soil-types.aspx>>.
- Haeg, Fritz. Edible Estates: Attack on the Front Lawn. New York: Metropolis, 2010. Print.
- Heintzman, Andrew, and Evan Solomon. Food and Fuel: Solutions for the Future. Toronto: House of Anansi, 2009. Print.
- Kisner, Corinne. "Urban Agriculture Case Study: Havana, Cuba." Climate Institute. Web. 09 June 2011. <<http://www.climate.org/topics/international-action/urban-agriculture/havana.htm>>.
- Madigan, Carleen. The Backyard Homestead. North Adams, MA: Storey Pub., 2009. Print.
- Nordahl, Darrin. Public Produce: the New Urban Agriculture. Washington, DC: Island, 2009. Print.
- Sample, Ian. "Global Food Crisis Looms as Climate Change and Population Growth Strip Fertile Land | Environment | The Guardian." The Guardian. 31 Feb. 2007. Web. 29 Apr. 2011. <<http://www.guardian.co.uk/environment/2007/aug/31/climatechange.food>>.
- Trail, Gayla. Grow Great Grub: Organic Food from Small Spaces. New York: Clarkson Potter, 2010. Print.
- Viljoen, André, Katrin Bohn, and J. Howe. Continuous Productive Urban Landscapes: Designing Urban Agriculture for Sustainable Cities. Oxford: Architectural, 2005. Print.



# FIGURE SOURCES

1.1 - <http://envirokid.files.wordpress.com/2010/01/w-meat2-harvester.jpg>

1.2 - <http://weblogs.baltimoresun.com/features/gardening/whitehouse%20garden.jpg>

1.3 - [http://farm3.static.flickr.com/2301/2378357218\\_3749e1f5d5.jpg](http://farm3.static.flickr.com/2301/2378357218_3749e1f5d5.jpg)

1.4 - [http://havanajournal.com/images/uploads/Organiponico\\_market.jpg](http://havanajournal.com/images/uploads/Organiponico_market.jpg)

1.5 - <http://oliver103.files.wordpress.com/2008/05/edible-estates-0042.jpg>

1.6 - [http://farm4.static.flickr.com/3643/3366267634\\_f40a8e6e6a.jpg](http://farm4.static.flickr.com/3643/3366267634_f40a8e6e6a.jpg)

2.1 - 2.39 - Illustrated by Joseph Cafuir

# APPENDIX



*Fig. 2.38 - Front yard prototype design (full graphic)*



Fig. 2.39 - Community garden prototype design (full graphic)

